

TRACTOR 980 ED especial - 980 E3 especial

pasquali



pasquali

NUEVA VERSION

Más fiable, más robusto,
más ergonómico y más...



SERIE 980 TRACTORES ARTICULADOS A 4 RM
4 W.D. ARTICULATED TRACTORS

980 ED ESPECIAL

980 E3 ESPECIAL



CATALOGO DE PIEZAS DE RECAMBIO

TRACTORES	
980 ED - Especial	980 E3 - Especial

EDICION	Septiembre-98		
---------	---------------	--	--

GRUPOS

981.002.1	Embrague	(Tr.980 ED-Esp)
738.002.1	Embrague	(Tr.980 E3-Esp)
981.003.1	Cambio	
981.004.1	Bujes Anteriores	
981.005.1	Mando Cambio	
981.008.1	Articulación Central - Dirección	
981.010.1	Posterior	
981.011.1	Bujes Posteriores	
981.017.1	Mando frenos y Embrague	



08191 RUBÍ (Barcelona) - Spain - Compositor Schubert, 7-19 - Tel. (93) 588 41 42 - Fax (93) 588 49 91 - Telex 94541 MAPA E
50041 Calenzano (Firenze) - Italy - Via Nuova, 30 - Tel. (055) 887 77 46 - Telex 571431 PAMA I

TRACTOR 980 ED especial - 980 E3 especial

pasquali

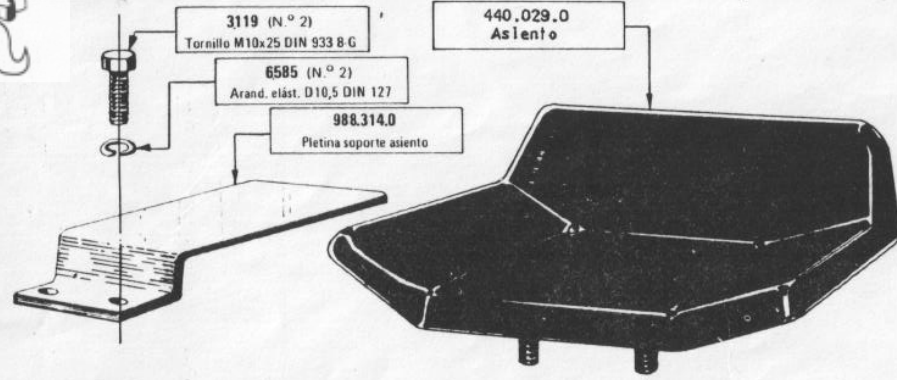

3119 (N.º 2)
Tornillo M10x25 DIN 933 8 G

440.029.0
Asiento

6585 (N.º 2)
Arand. elást. D10,5 DIN 127

988.314.0
Pletina soporte asiento

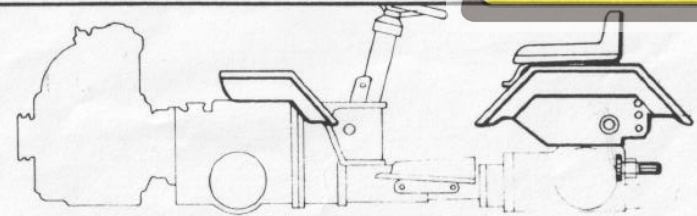

990.117.0
Guardabarros ant. derecho

3105 (N.º 2)
Tornillo M8x16 DIN 933 8 G

6583 (N.º 2)
Arandela elást. D8,4 DIN 127

991.351.0
Guardabarro trasero Derech

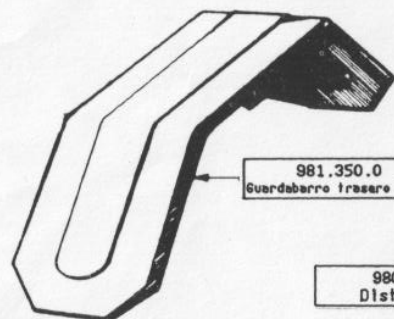
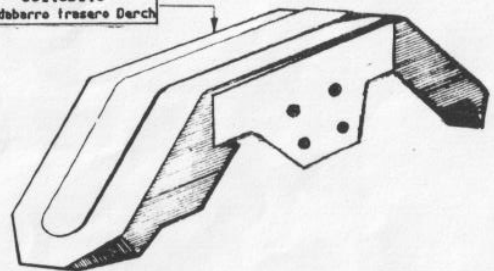

981.350.0
Guardabarro trasero Izqda

984.842.0
Rodamiento 6305 N

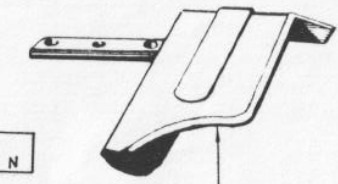

990.116.0
Guardabarros ant. izquierdo

980.010.0

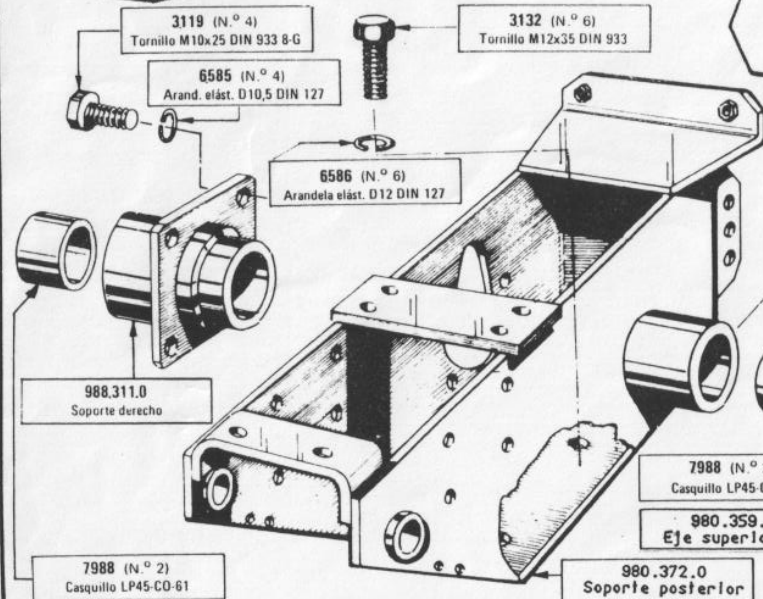

3119 (N.º 4)
Tornillo M10x25 DIN 933 8 G

3132 (N.º 6)
Tornillo M12x35 DIN 933

6585 (N.º 4)
Arand. elást. D10,5 DIN 127

6586 (N.º 6)
Arandela elást. D12 DIN 127

7929 (N.º 2)
Engrasador

6773
Anillo seeger 35 Din-471

980.345.1
Distanciadlor

z 32

980.356.0
Enguaje T.F superior

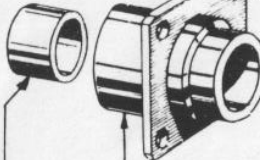

988.311.0
Soporte derecho

984.707.0
Retén apoyo rotor

980.343.1
Tapeta posterior

980.346.0
Junta tapeta

8266
Rodamiento 6207

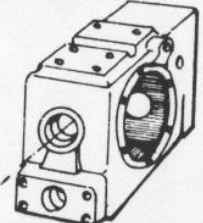

7988 (N.º 2)
Casquillo LP45-CO-61

7988 (N.º 2)
Casquillo LP45-CO-61

980.359.1
Eje superior T.F

980.372.0
Soporte posterior

3107 (N.º 4)
Torn. M-8x20 Din-933

6583 (N.º 4)
Arandela elást. D-8,4

GRUPO POSTERIOR hoja-2	
Modelos	
Tr-991 E	
Tr-980 EX	
Tr-980 ED-Base	

pasquali

EDICION
Abri11 - 96

TRACTOR 980 ED especial - 980 E3 especial

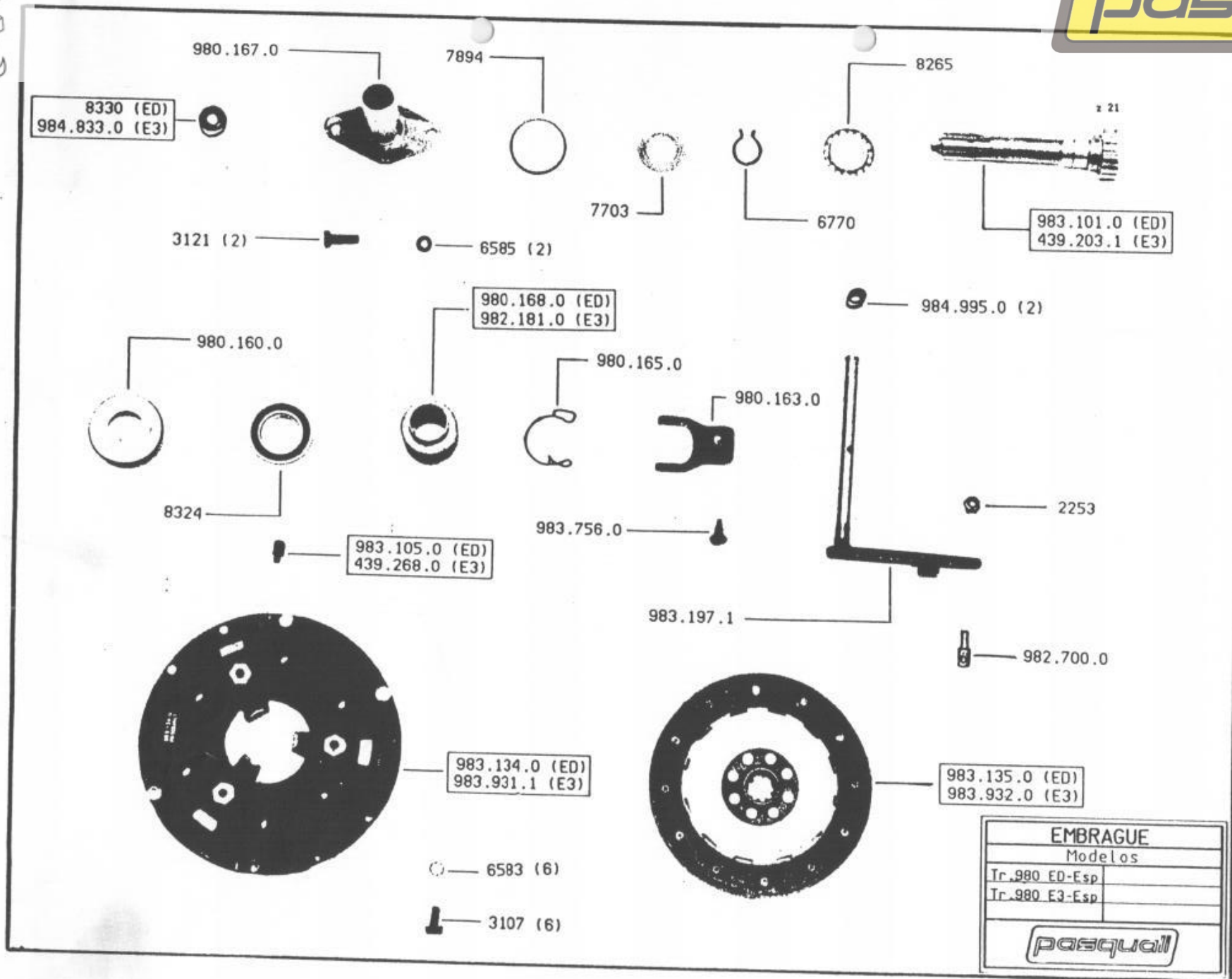

981.002.1
738.002.1

EDICION	
Septiembre-98	

EMBRAGUE	
Modelos	
Tr. 980 ED-Esp	
Tr. 980 E3-Esp	

TRACTOR 980 ED especial - 980 E3 especial

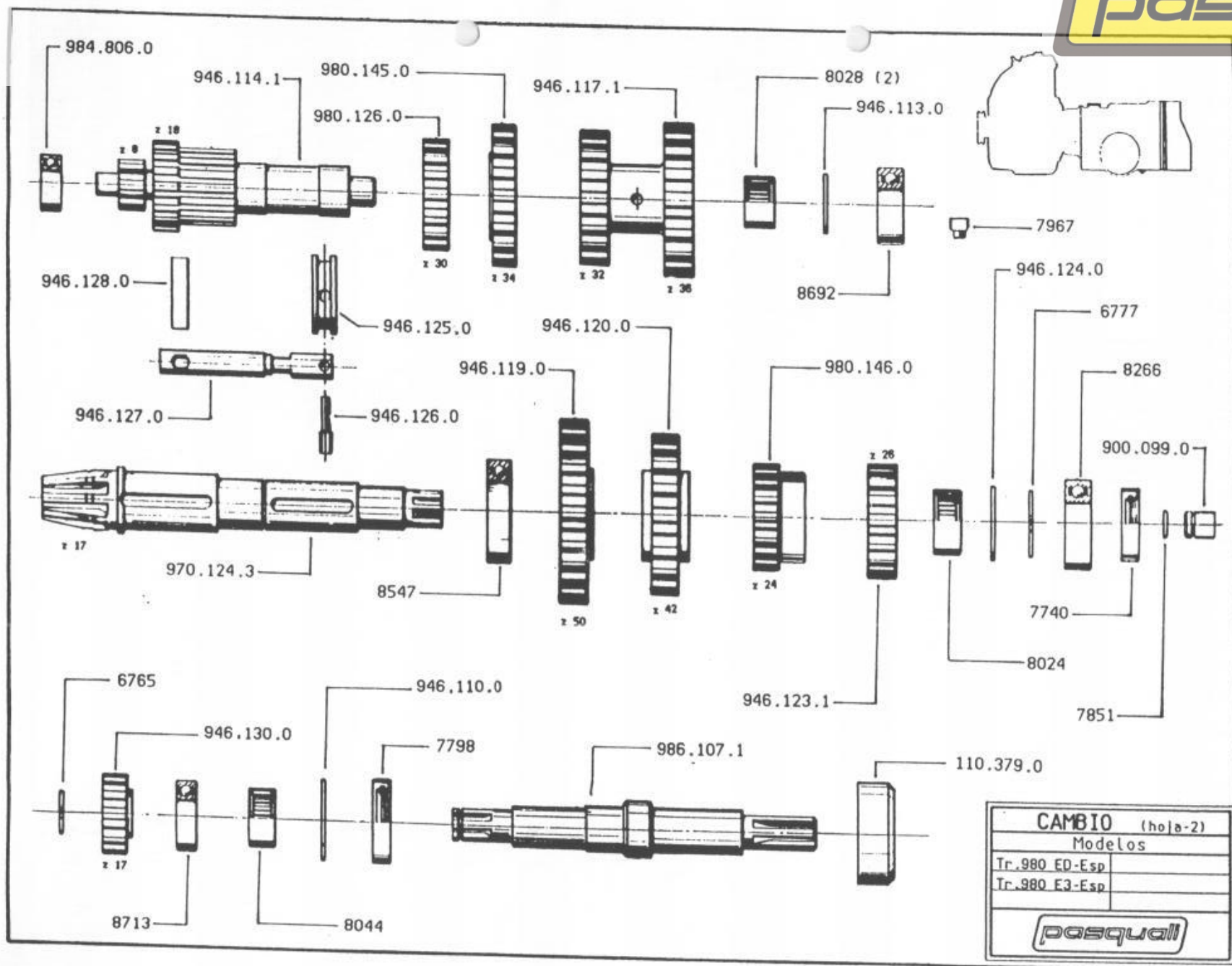

981.003.1

CAMBIO (hoja-2)	
Modelos	
Tr.980 ED-Esp	
Tr.980 E3-Esp	

EDICION
Septiembre-98

TRACTOR 980 ED especial - 980 E3 especial

pasquali

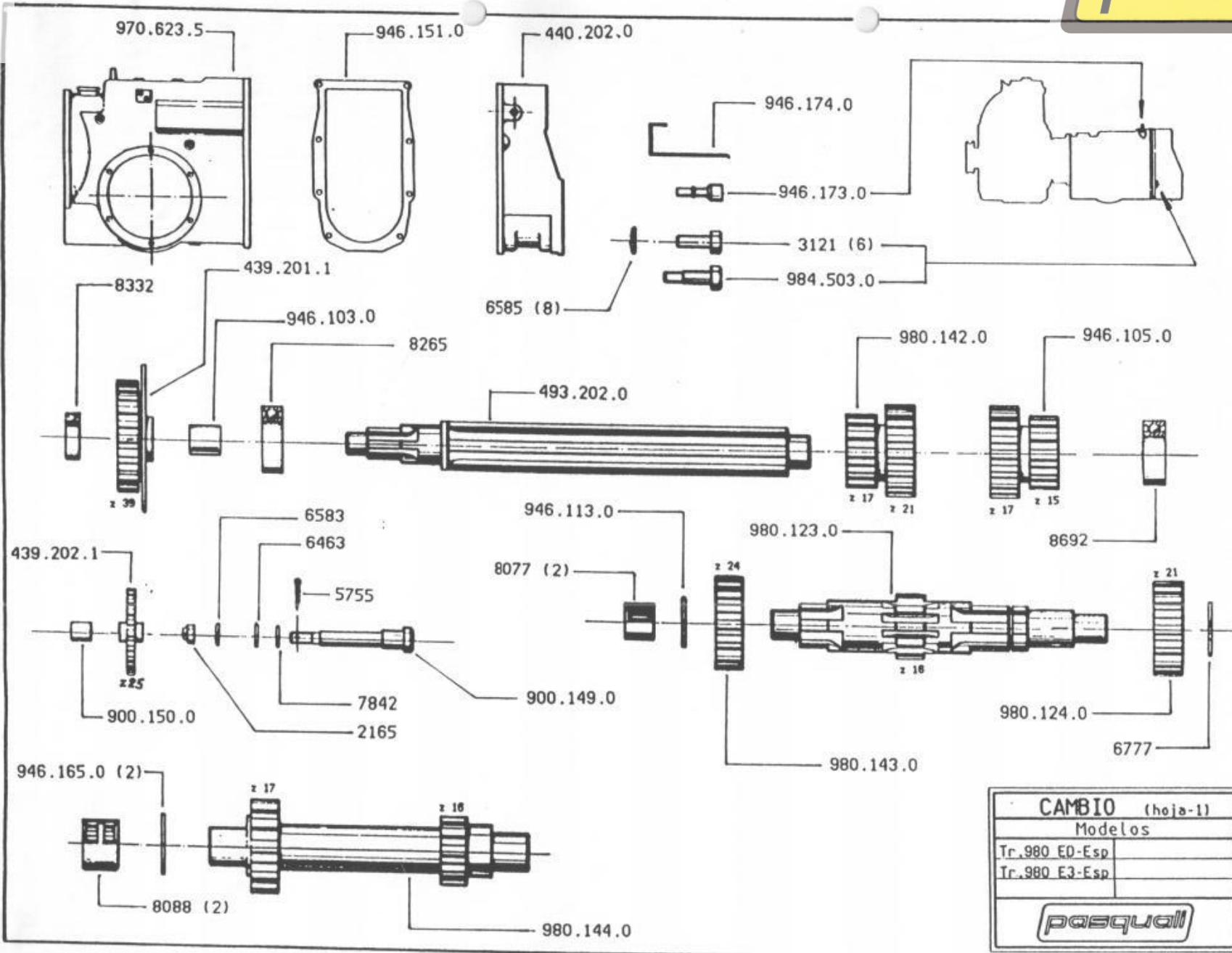

981.003.1

CAMBIO (hoja-1)	
Modelos	
Tr.980 ED-Esp	
Tr.980 E3-Esp	
pasquali	

Septiembre-98	EDICION
---------------	----------------

TRACTOR 980 ED especial - 980 E3 especial

pasquali

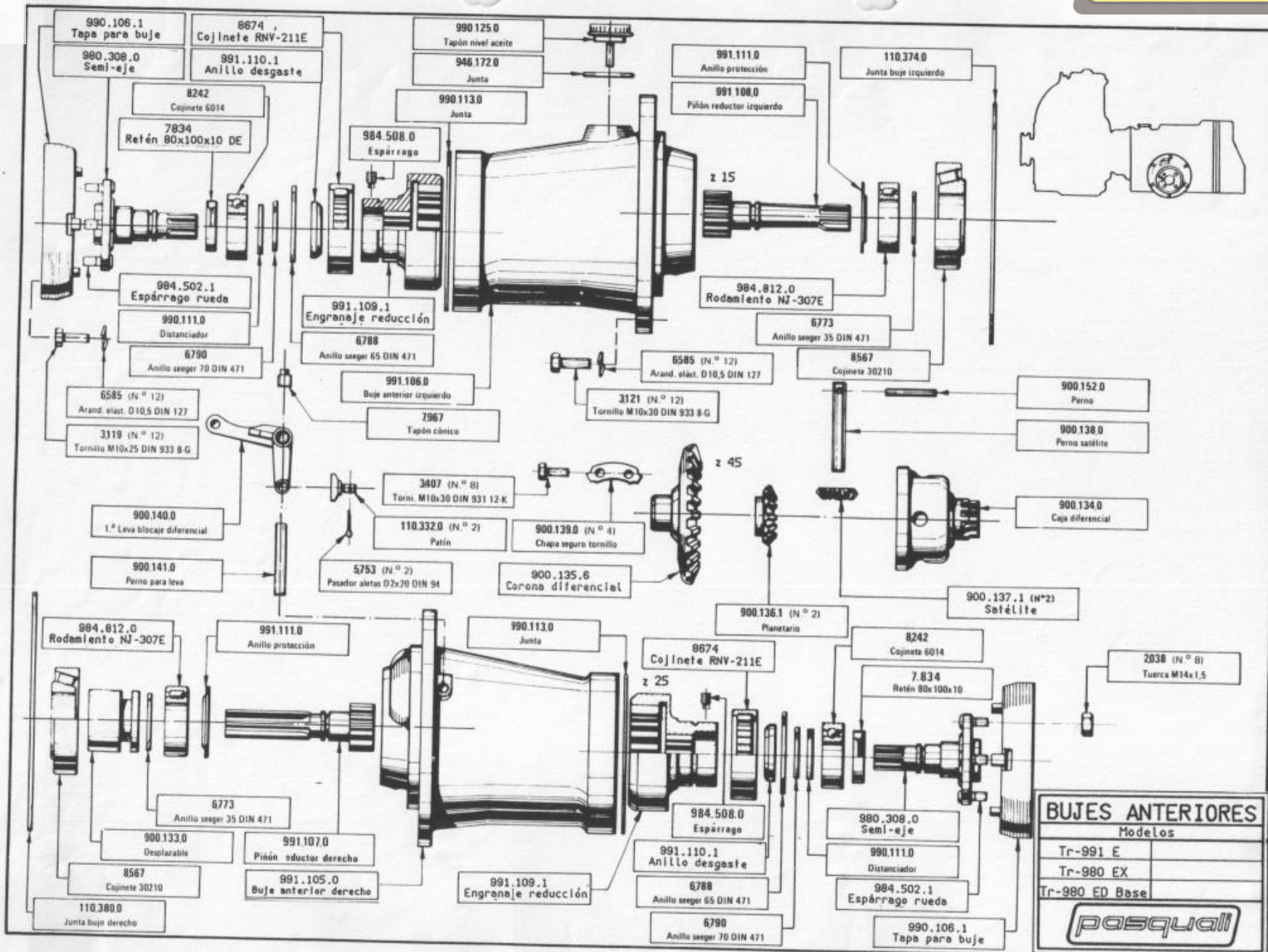

980.004.0

BUJES ANTERIORES	
Modelos	
Tr-991 E	
Tr-980 EX	
Tr-980 ED Base	

pasquali

EDICION
Abril - 96

TRACTOR 980 ED especial - 980 E3 especial

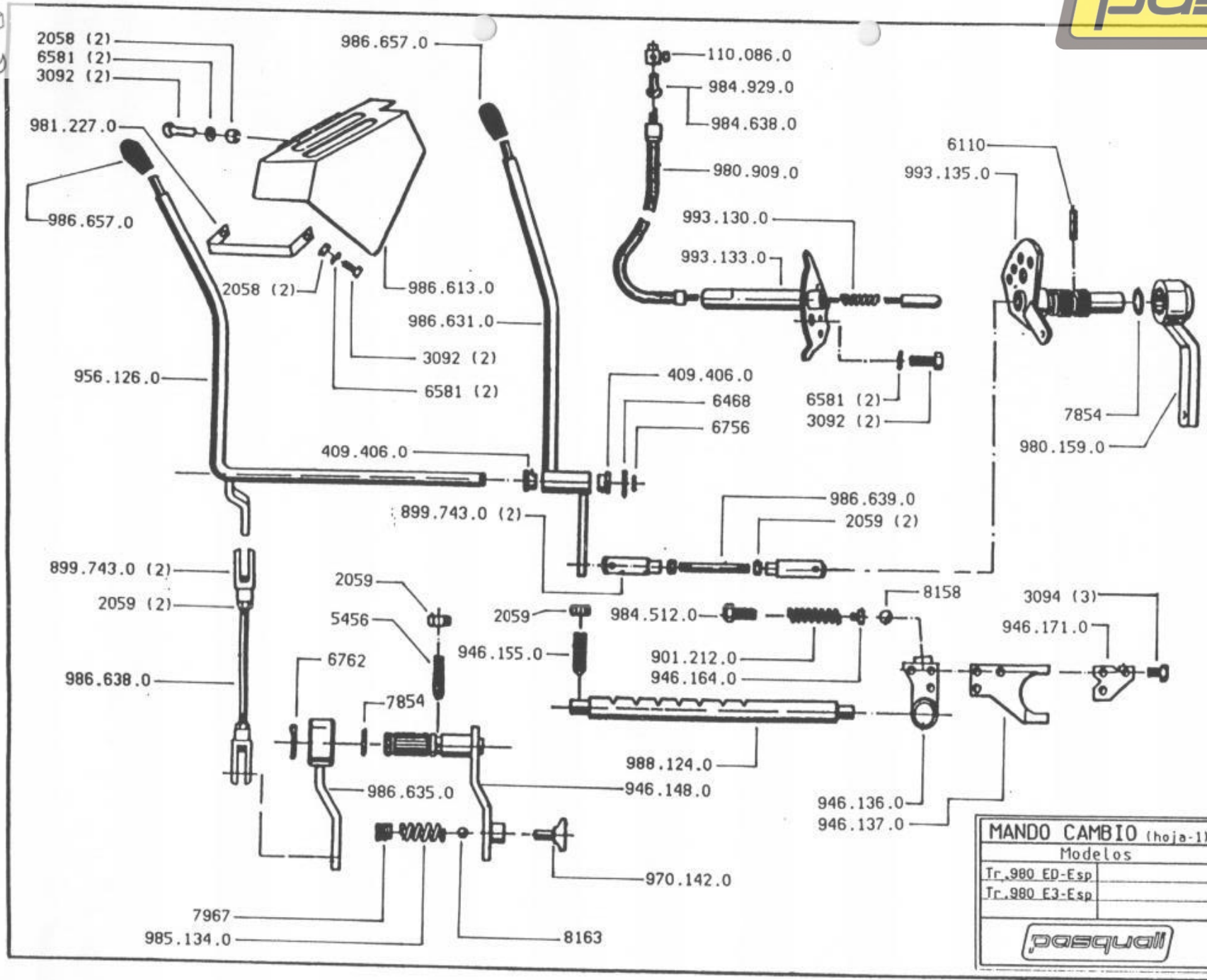

981.005.1

MANDO CAMBIO (hoja-1)	
Modelos	
Tr. 980 ED-Esp	
Tr. 980 E3-Esp	

Septiembre-98	EDICION
---------------	----------------

TRACTOR 980 ED especial - 980 E3 especial

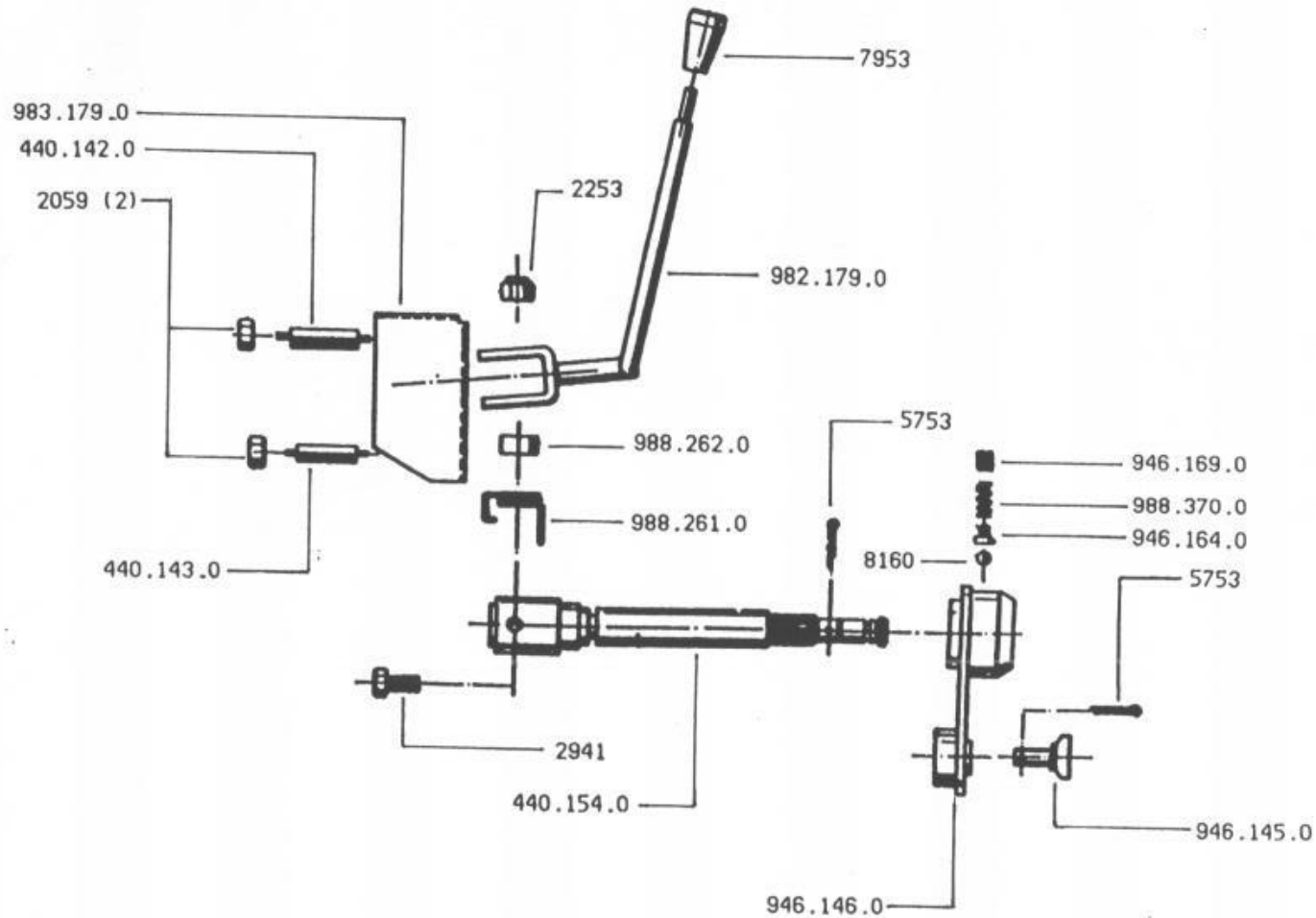

981.005.1

MANDO CAMBIO (hoja-2)	
Modelos	
Tr. 980 ED-Esp	
Tr. 980 E3-Esp	

Septiembre-98	EDICION
---------------	----------------

TRACTOR 980 ED especial - 980 E3 especial

pasquali

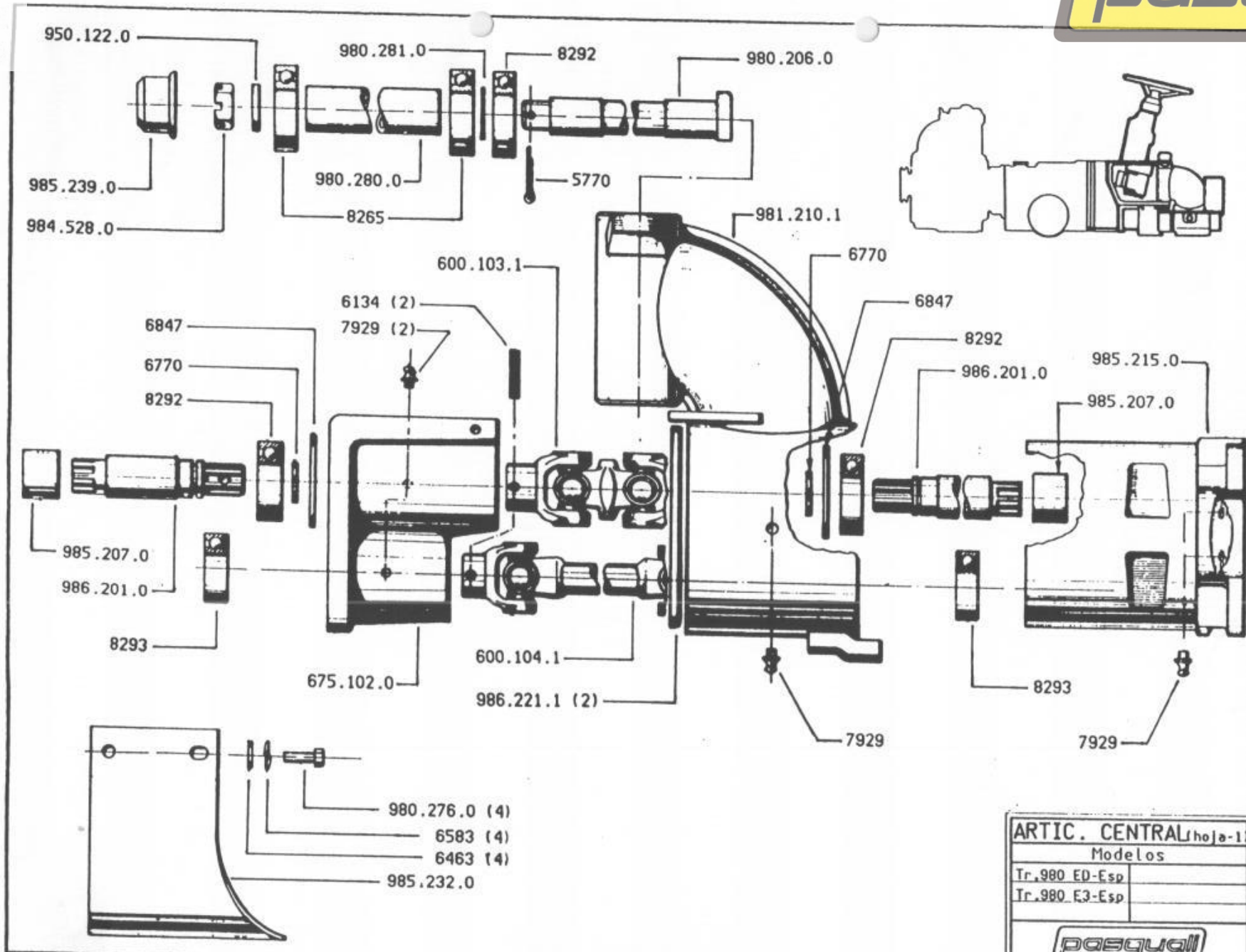

ARTIC. CENTRAL (hoja-1)	
Modelos	
Tr. 980 ED-Esp	
Tr. 980 E3-Esp	
pasquali	

Septiembre-98	EDICION

TRACTOR 980 ED especial - 980 E3 especial

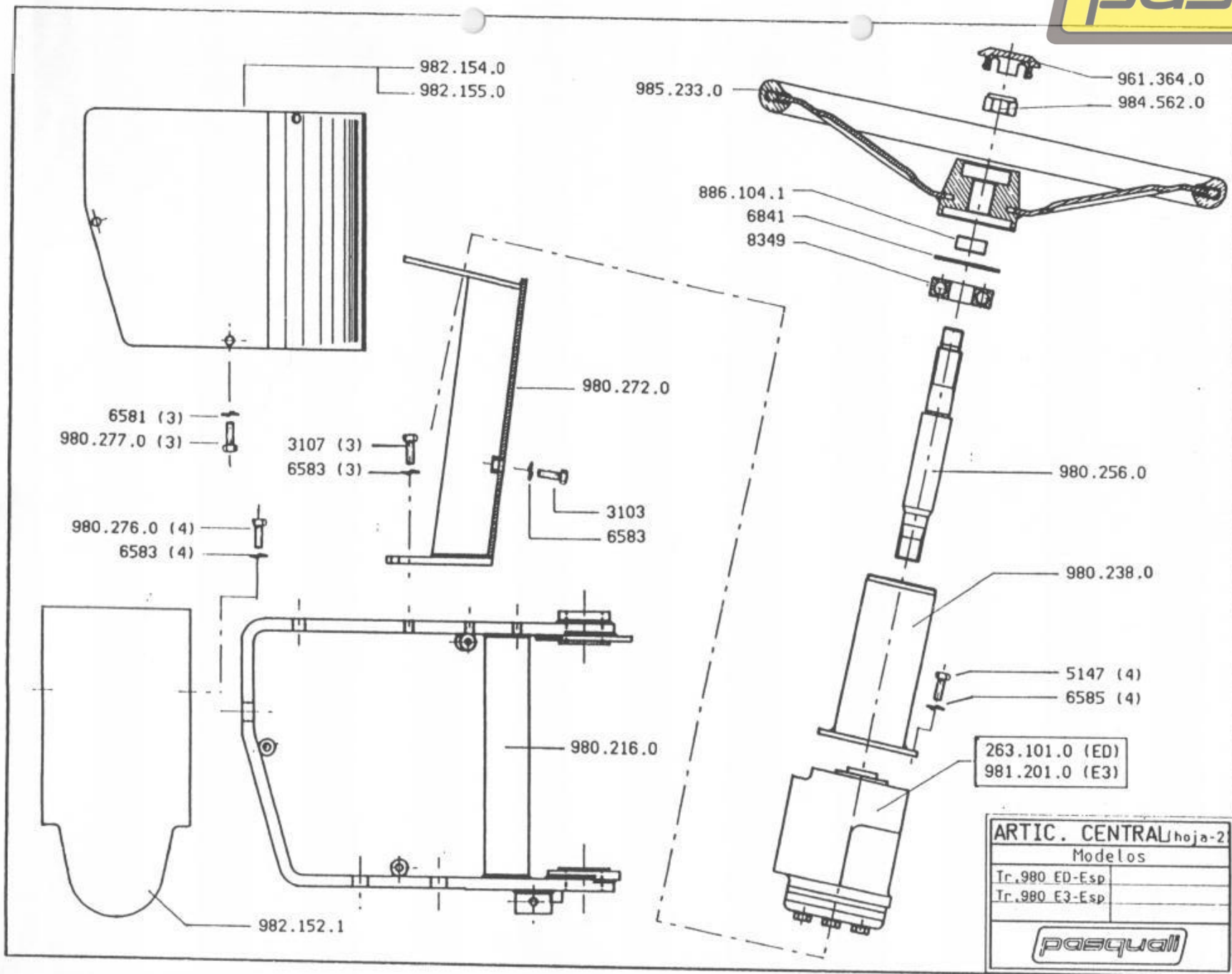

981.008.1

ARTIC. CENTRAL hoja-2	
Modelos	
Tr.980 ED-Esp	
Tr.980 E3-Esp	

EDICION	Septiembre-98
---------	---------------

TRACTOR 980 ED especial - 980 E3 especial

pasquali

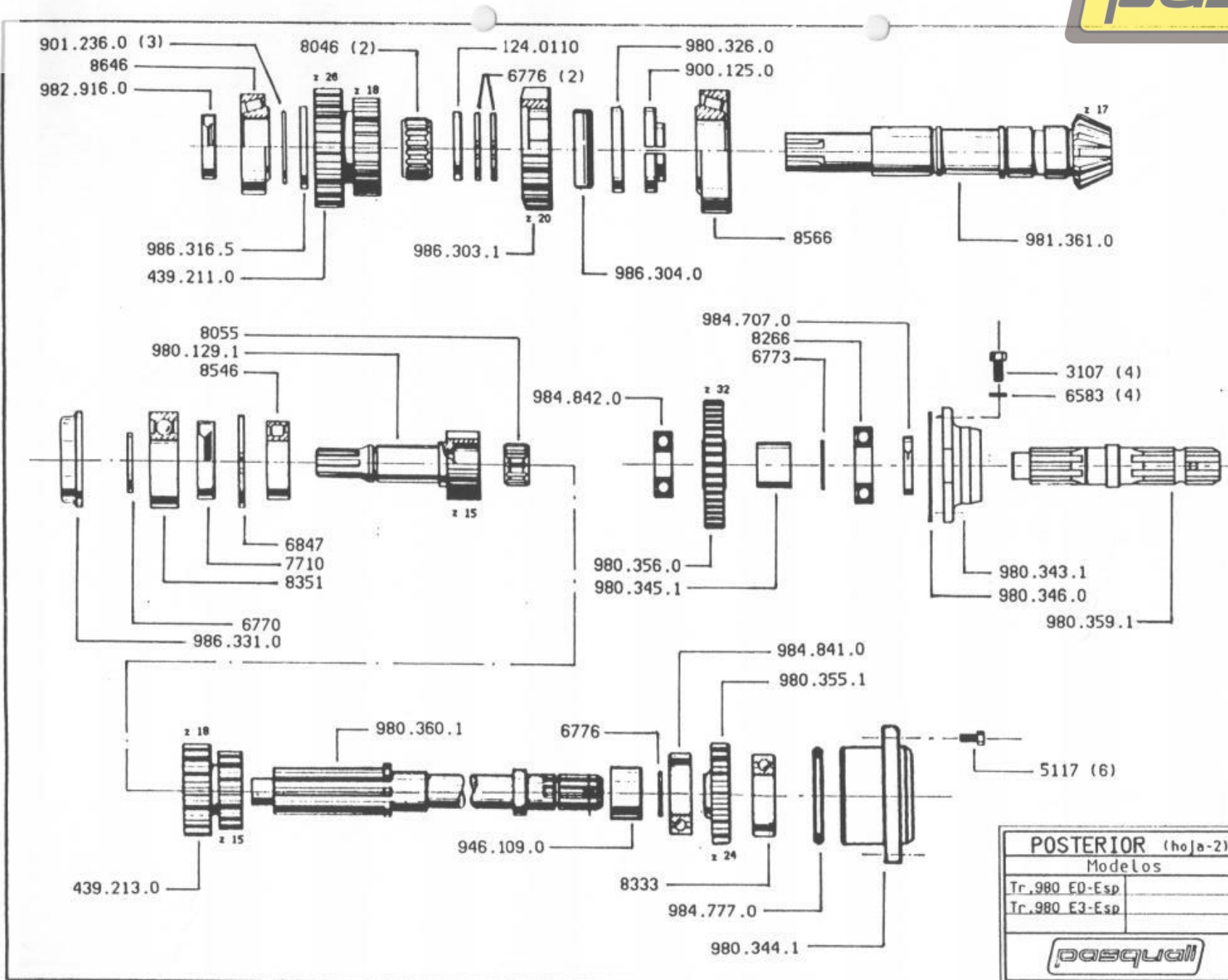

981.010.1

POSTERIOR (hoja-2)	
Modelos	
Tr.980 ED-Esp	
Tr.980 E3-Esp	
pasquali	

EDICION
Septiembre-98

TRACTOR 980 ED especial - 980 E3 especial

pasquali

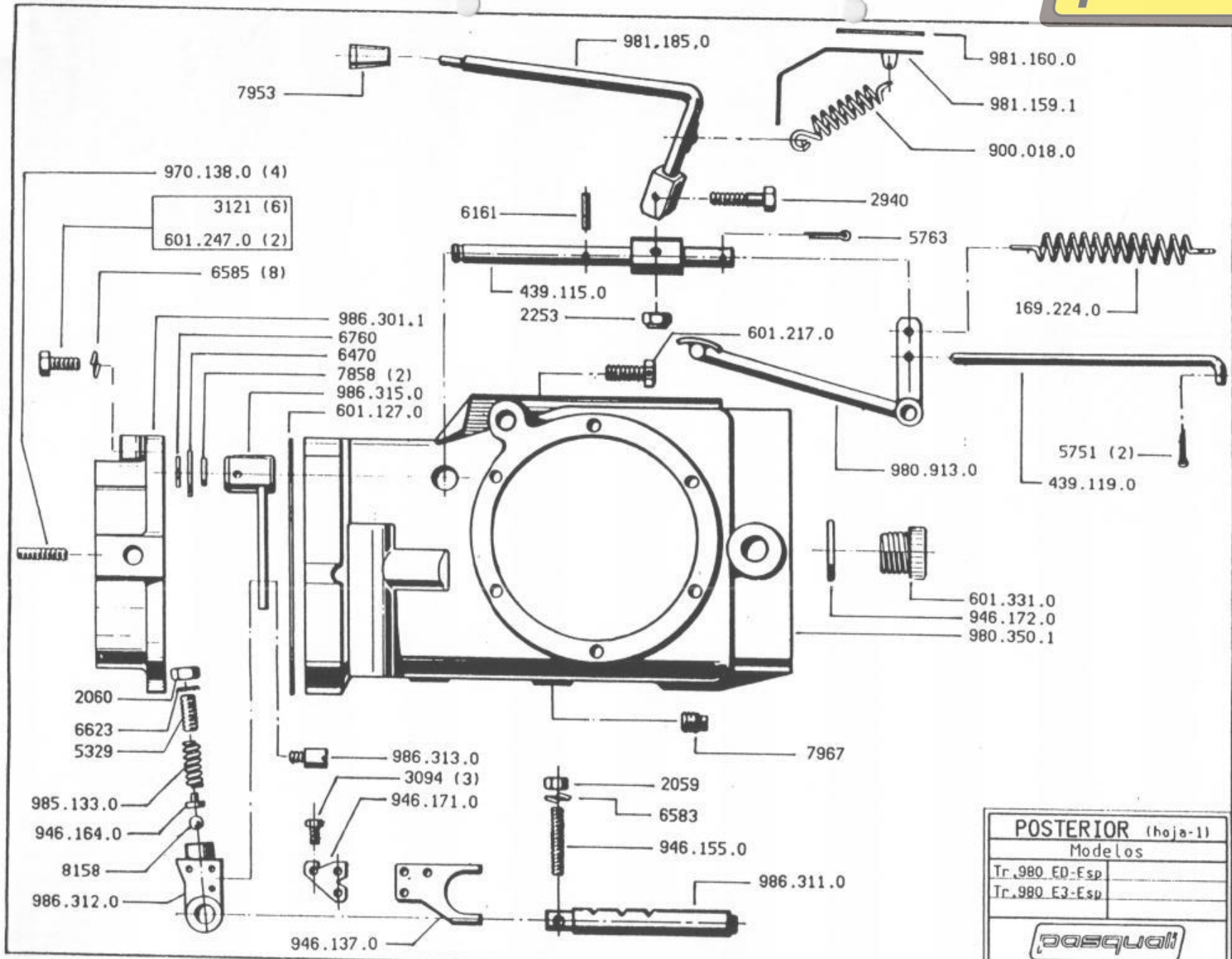

981.010.1

POSTERIOR (hoja-1)	
Modelos	
Tr.980 ED-Esp	
Tr.980 E3-Esp	
pasquali	

Septiembre-98	EDICION
---------------	---------

TRACTOR 980 ED especial - 980 E3 especial

pasquali

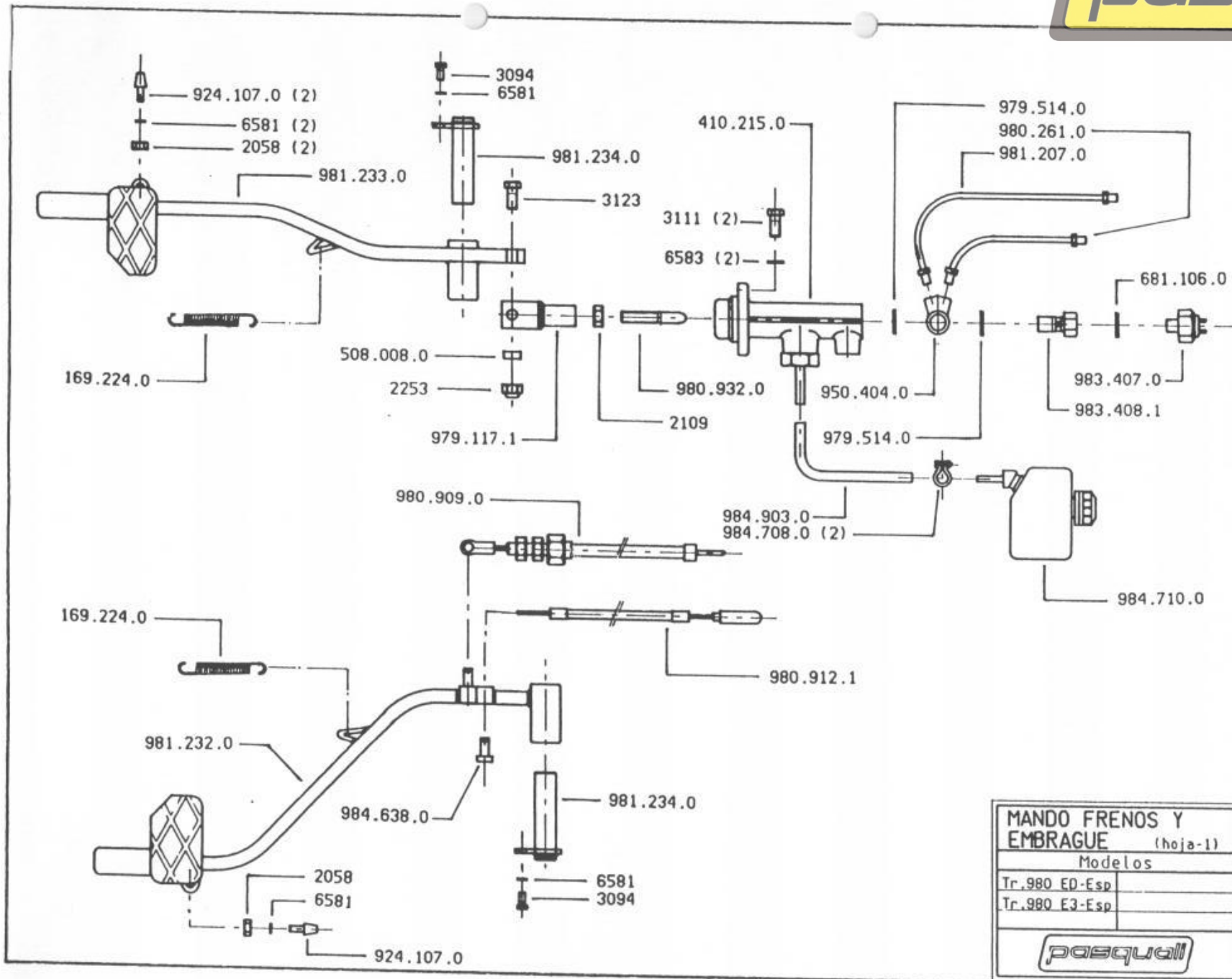

981.011.1

MANDO FRENOS Y EMBRAGUE (hoja-1)	
Modelos	
Tr.980 ED-Esp	
Tr.980 E3-Esp	
pasquali	

Septiembre-98	EDICION
---------------	----------------

TRACTOR 980 ED especial - 980 E3 especial

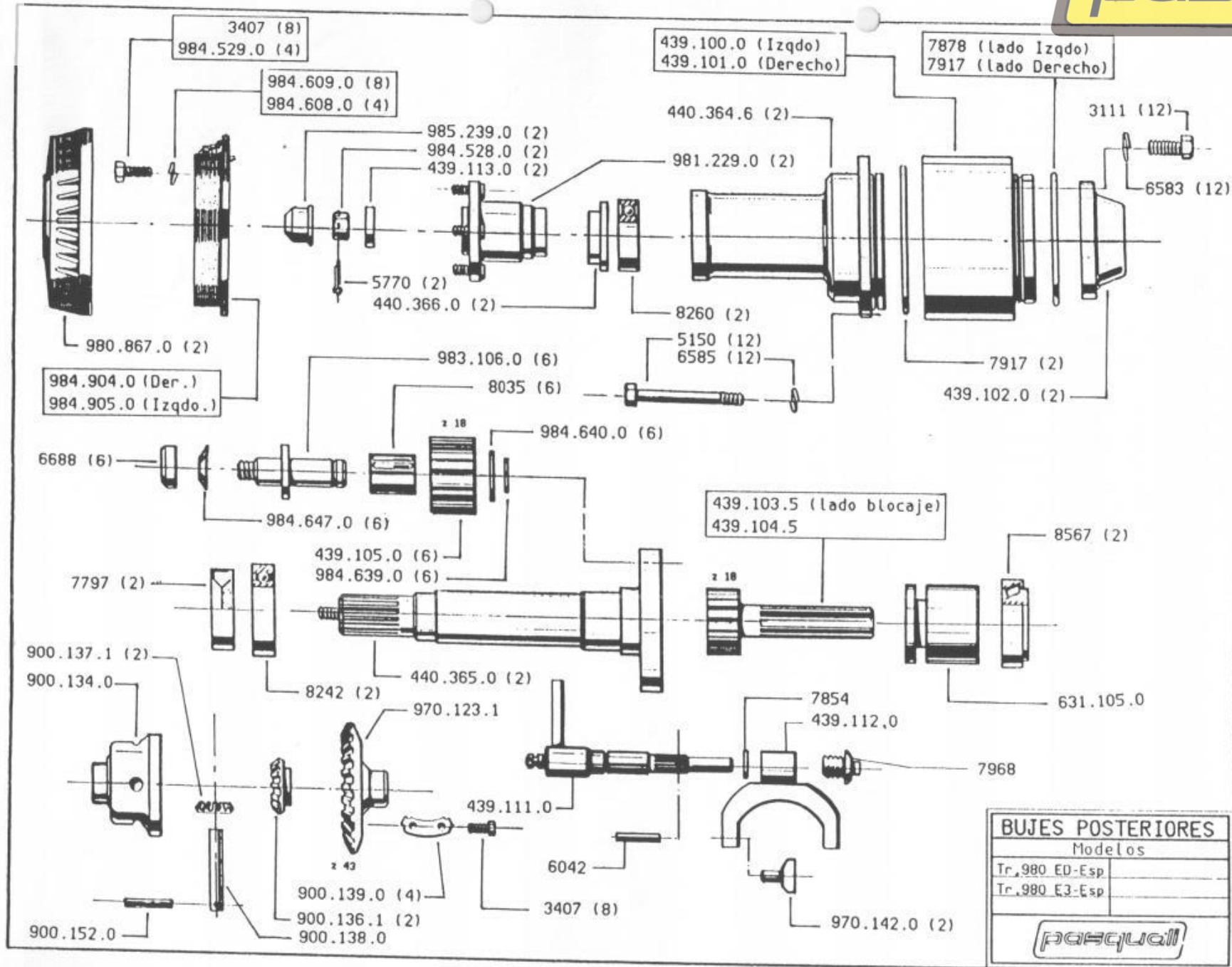

981.011.1

BUJES POSTERIORES	
Modelos	
Tr. 980 ED-Esp	
Tr. 980 E3-Esp	

EDICION
Septiembre-98

TRACTOR 980 ED especial - 980 E3 especial

pasquali

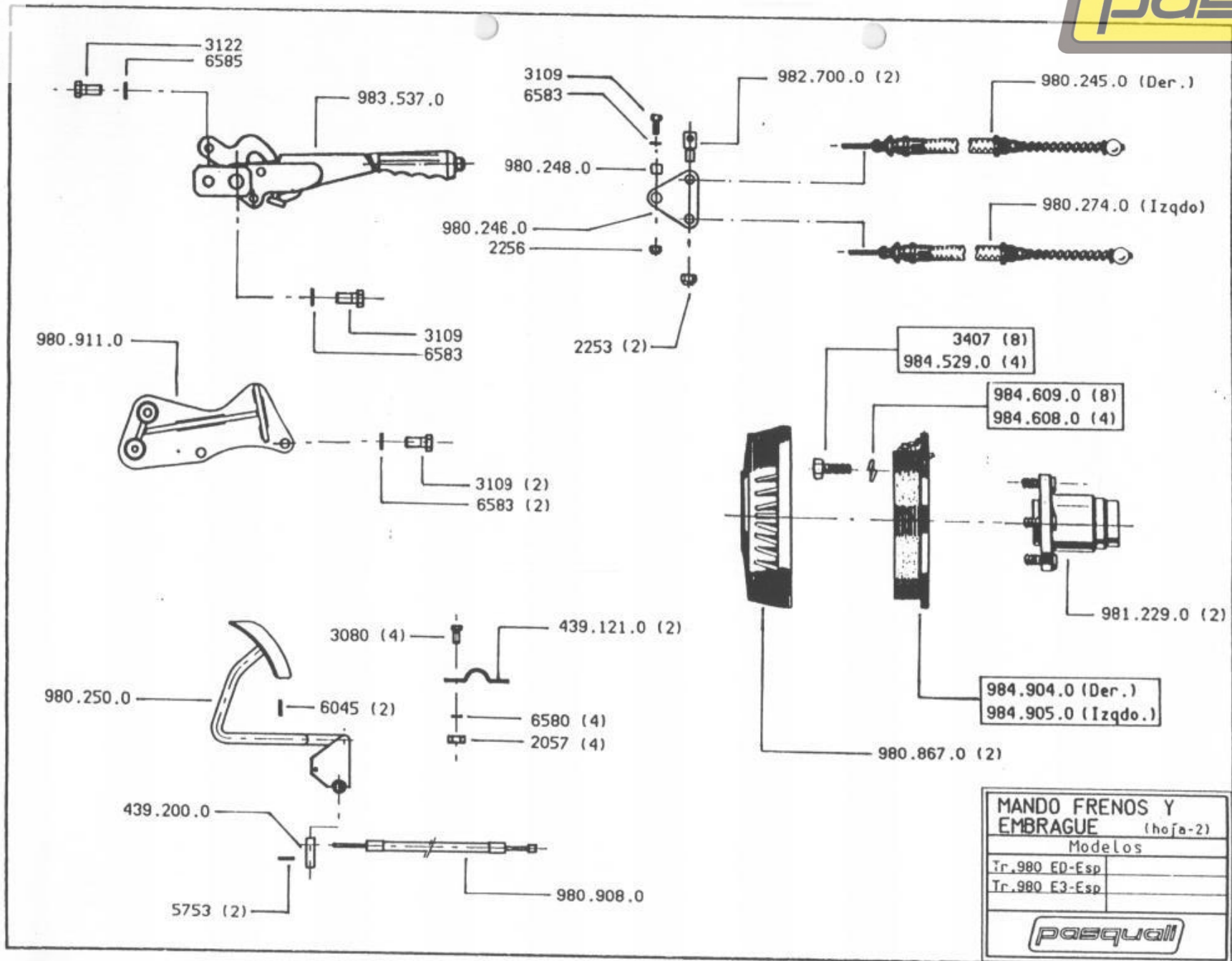

981.011.1

MANDO FRENOS Y EMBRAGUE (hoja-2)	
Modelos	
Tr.980 ED-Esp	
Tr.980 E3-Esp	
pasquali	

Sep.1embre-98	EDICION
---------------	----------------

TRACTOR 980 ED especial - 980 E3 especial



REFERENCIA	DENOMINACION DE LA PIEZA	981.42	981.43	738.42	738.43	REFERENCIA	DENOMINACION DE LA PIEZA	981.42	981.43	738.42	738.43
2.013	TUERCA M-20 (DIN-934)	4	4	4	4	5.157	TORNILLO ALLEN M-12X30 DIN 912		3		3
2.021	TUERCA M-14X200 ALTA (S/PLANO)	8	8	8	8	5.178	TORNILLO M-14X30 DIN-912	4		4	4
2.038	TUERCA M-14X1,5 (SPLANO)	38	38	38	38	5.329	TORNILLO M-10X20 DIN-913	1	1	1	1
2.056	TUERCA M-4 DIN-934	7	7	7	7	5.397	ESPARRAGO M-10X20 DIN-916	1	1	1	1
2.057	TUERCA M-5 DIN-934	17	17	17	17	5.399	TORNILLO ESPE.M-14X1,5	1	1	1	1
2.058	TUERCA M-6 DIN-934	21	21	21	21	5.447	TORNILLO M-6X20 DIN-915	1	1	1	1
2.059	TUERCA M-8 DIN-934	28	28	28	28	5.456	ESPARRAGO M-8X25 DIN-915	1	1	1	1
2.060	TUERCA M-10 DIN-934	24	24	24	24	5.555	TORNILLO M-8X16 DIN-7991-12K	2	2	2	2
2.061	TUERCA M-12 DIN-934	11	11	11	11	5.750	PASADOR ALET.1,5X12 DIN-94 N-10	1	1	1	1
2.062	TUERCA M-14 DIN-934 UNI-5588	4	6	4	6	5.751	PASADOR ALETAS A-1,5X15 DIN-94	2	2	2	2
2.108	TUERCA M-8 DIN-936	1	1	1	1	5.753	PASADOR ALETAS 2X14 DIN-94	4	4	4	4
2.109	TUERCA M-10 DIN-936	5	5	5	5	5.755	PASADOR ALETAS 2X20 DIN-94 N-10	1	1	1	1
2.111	TUERCA M-14 DIN 936	4	4	4	4	5.758	PASADOR ALETAS 3X20 DIN-94 N-10	4	4	4	4
2.165	TUERCA ALMENADA M-8 DIN-935	1	1	1	1	5.763	PASADOR ALETA 4X28 DIN-94 N-102	2	2	2	2
2.208	TUERCA ALTA M10X1,5	2	2	2	2	5.765	PASADOR ALETAS 4X40 DIN-94 N-10	1	1	1	1
2.253	TUERCA AUTOBLOCANTE M-10 NYLON	5	5	5	5	5.769	PASADOR ELASTICO 5X40 DIN-94	1	1	1	1
2.256	TUERCA AUTOBLOCANTE M-8 NYLON	6	7	6	7	5.770	PASADOR ALETAS 5X45 DIN-94 N-10	5	5	5	5
2.257	TUERCA AUTOBLOCANTE M-6	4	4	4	4	5.812	PASADOR ALETAS 4X30 DIN-94 N-10	1	1	1	1
2.828	TORN. M-6X55 (DIN-933)	2	2	2	2	6.040	PASADOR ELASTICO 3X20 DIN-1481	2	2	2	2
2.832	TORNILLO M-8X35 DIN-931 8-8	6	6	6	6	6.042	PASADOR ELASTICO 3X25 DIN-1481	1	1	1	1
2.834	TORNILLO M-8X45 DIN-931 8-8	1	1	1	1	6.045	PASADOR ELASTICO 3X30 DIN-1481	2	2	2	2
2.932	TORNILLO M-8X50 DIN-931 8-8	1	1	1	1	6.066	PASADOR ELASTICO 3,5X24 DIN-148	1	1	1	1
2.933	TORN.M-8X55 DIN-931 8-8 UNI-573	4	2	4	2	6.084	PASADOR ELASTICO 4X20 DIN-1481	2	2	2	2
2.940	TORNILLO M10X55 DIN-931	1	1	1	1	6.086	PASADOR ELASTICO 4X25 DIN-1481	1	1	1	1
2.941	TORNILLO M-10X60 DIN-931 8-8	7	7	7	7	6.110	PASADOR ELASTICO 5X35 DIN-1481	1	1	1	1
2.942	TORNILLO M-10X65DIN-931 UNI-573	2	2	2	2	6.134	PASADOR ELASTICO 6X35 DIN-1481	2	2	2	2
3.080	TORNILLO M-5X16 DIN-933	8	8	8	8	6.161	PASADOR ELASTICO 7X30 DIN-1481	2	2	2	2
3.082	TORNILLO 5X20 UNI 5735	2	2	2	2	6.187	PASADOR ELAST. 8X50 DIN 1481	1	1	1	1
3.092	TORNILLO M-6X12 DIN-933	5	5	5	5	6.426	LLAVE 19 22	1	1	1	1
3.094	TORNILLO M-6X16 DIN-933 8-8	12	12	12	12	6.429	LLAVE FIJA 10/13	1	1	1	1
3.097	TORNILLO M-6X22 DIN-933 8-8	3	3	3	3	6.460	ARANDELA 5,3 DIN-6592	4	4	4	4
3.098	TORNILLO M-6X25 DIN-933 8-8	4	4	4	4	6.461	ARANDELA PLANA 0 6,4 DIN-125A		11		11
3.101	TORNILLO M-6X35 DIN-933 8-8	1	1	1	1	6.463	ARANDELA PLANA 0,4 DIN-125A	19	19	19	19
3.103	TORNILLO M-8X12 DIN-933 8-8	1	1	1	1	6.470	ARANDELA PLANA 0-19X34X30DIN-125	1	1	1	1
3.105	TORNILLO M-8X16 DIN-933 8-8	2	1	2	1	6.579	ARANDELA BROWER D-4,3 DIN-127	2	2	2	2
3.107	TORNILLO M-8X20 DIN-933 8-8	8	8	8	8	6.580	ARANDELA BROWER D-5,3 DIN-127	14	14	14	14
3.109	TORNILLO M-8X25 DIN-933 8-8	3	3	3	3	6.581	ARANDELA ELASTICA D-6,4 DIN-127	16	32	16	16
3.111	TORNILLO M-8X30 DIN-933 8-8	14	14	14	14	6.583	ARANDELA ELASTICA D-8,4 DIN-127	64	54	64	54
3.113	TORNILLO M-8X40 DIN-933 UNI-573	4	4	4	4	6.585	ARANDELA ELASTICA D-10,5DIN-127	104	104	104	104
3.115	TORNILLO M-10X16 DIN-933 8-8	2	2	2	2	6.586	ARANDELA ELASTICA D-12 DIN-127	24	24	24	24
3.117	TORNILLO M-10X20 DIN-933	14	14	14	14	6.588	ARANDELA ELASTICA D-14 DIN-127	24	20	24	20
3.119	TORNILLO M-10X25 DIN-933 8-8	26	26	26	26	6.589	ARANDELA ELASTICA D-16 DIN-127	4	4	4	4
3.121	TORNILLO M-10X30 DIN-933 8-8	40	40	40	40	6.623	ARANDELA DENTADA INT.0-10 DIN-6	2	2	2	2
3.122	TORNILLO M-10X35 DIN-933	27	27	27	27	6.626	ARANDELA DENT.D-16,5 DIN-6797J	1	1	1	1
3.123	TORNILLO M-10X40 DIN-933 8-8	1	1	1	1	6.666	ARANDELA D.INT-14 (DIN-2093)	4	4	4	4
3.127	TORNILLO M-12X20DIN-933 UNI-573	2	4	2	2	6.688	TUERCA M-17X1 AUTOBLOC.SKf	12	12	12	12
3.131	TORNILLO M-12X30 DIN-933	26	26	26	26	6.719	ARANDELA DE FIBRA 14X22X2,5	2	2	2	2
3.132	TORNILLO M-12X35 DIN-933	6	6	6	6	6.722	ARANDELA DE FIBRA	2	2	2	2
3.133	TORNILLO M-12X40 DIN-933	4	4	4	4	6.749	ANILLO ELASTICO 12 DIN 6799		1		1
3.142	TORNILLO M-14X25 DIN-933 8-8	3	3	3	3	6.750	ANILLO SEEGER 8 UNI 7435	4	4	4	4
3.144	TORNILLO M-14X30 DIN-933 8-8	8	8	8	8	6.760	ANILLO SEGURIDAD E-18 DIN-471	2	2	2	2
3.145	TORNILLO M-14X35 DIN-933 8-8	10	10	10	10	6.765	ANILLO SEEGER E-20 DIN-471	3	3	3	3
3.157	TORNILLO M16X40 DIN 932	4	4	4	4	6.766	ANILLO SEEGER E-24 DIN-471	1	1	1	1
3.289	TORNILLO M-12X16 DIN-961 88	4	4	4	4	6.767	ANILLO SEEGER 25 DIN-471	3	3	3	3
3.290	TORNILLO M-12X30 DIN-961 88	4	4	4	4	6.770	ANILLO D-26 DIN 471	2	2	2	2
3.354	TAPON M-14X14	2	2	2	2	6.773	ANILLO SEEGER E-30 DIN-471	1	1	1	1
3.407	TORNILLO M-10X30 DIN-931 12-K	24	24	24	24	6.776	ANILLO SEEGER 35 DIN-471	1	1	1	1
3.426	TORNILLO M-12X1,25X25 DIN-933	4	4	4	4	6.777	ANILLO SEEGER 40 DIN-471	2	2	2	2
3.507	TORNILLO M-5X10 DIN-84 UNI-6107	8	8	8	8	6.778	ANILLO SEEGER E-42 DIN-471	4	4	4	4
3.516	TORNILLO M-5X30 DIN-84	3	3	3	3	6.841	ANILLO SEEGER E 45 DIN 471	2	2	2	2
3.524	TORNILLO 6X16 UNI-6107	4	4	4	4	6.847	ANILLO SEEGER 52 DIN-472	1	1	1	1
3.795	TORNILLO M-4X13 DIN-86	6	6	6	6	6.864	ANILLO SEEGER 110 DIN-472	3	3	3	3
4.537	TORNILLO M-6X15 UNI 5732 DIN603	10	10	10	10	6.916	MUELLE 12,2X25X1,50 DIN-2093	2	2	2	2
4.539	TORNILLO M-6X25 UNI 5732 DIN603	2	2	2	2	7.147	REMACHE 6X20	3	3	3	3
4.965	TORNILLO B 4.2X13 DIN 7981	6	6	6	6	7.440	REMACHE HELECOIDAL 2,9X5 ALUMIN	4	4	4	4
5.117	TORNILLO M-6X16 DIN 912	6	6	6	6	7.703	RETEN 30X52X7 VITON	1	1	1	1
5.119	TORNILLO M-6X20 DIN-912 8-8	6	6	6	6	7.710	RETEN 30X62X10 DOBLE EFECTO	1	1	1	1
5.120	TORN.M-6X25 DIN-912 8-8 DIN-912	7	7	7	7	7.740	RETEN 35/62/10 DOBLE EFECTO	1	1	1	1
5.121	TORNILLO ALLEN M-6X30DIN-912 8-	3	3	3	3	7.797	RETEN 70X95X13	4	4	4	4
5.123	TORNILLO M-6X40 UNI5931	1	1	1	1	7.798	RETEN 35X55X10 D.E.	4	4	4	4
5.128	TORNILLO M8X16 DIN 912	2	2	2	2	7.842	JUNTA TORICA 7,65X1,78	2	2	2	2
5.146	TORNILLO M10X25 DIN 912	9	9	9	9	7.848	JUNTA TORICA 10,78X2,62	1	1	1	1
5.147	TORNILLO ALLEN M-10X30DIN-912 8	12	12	12	12	7.850	JUNTA TORICA OR 11,91X2,62	2		2	
5.150	TORNILLO M-10X120 DIN-912 86	24	24	24	24				1		1

REFERENCIA - DENOMINACION
CANTIDAD POR MAQUINA

EDICION	Septiembre-98
---------	---------------

TRACTOR 980 ED especial - 980 E3 especial



REFERENCIA	DENOMINACION DE LA PIEZA	981.42	981.4	738.42	738.43	REFERENCIA	DENOMINACION DE LA PIEZA	981.42	981.43	738.42	738.43
7.851	JUNTA TORICA 12,37X2,62	1	1	1	1	439.103.5	EJE PLANETARIO BLOCAJE	1	1	1	1
7.854	JUNTA TORICA 15,1X2,7	5	5	5	5	439.104.6	EJE PLANETARIO	3	3	3	3
7.856	JUNTA TORICA D-INT 15,88X2,62	2	2	2	2	439.106.0	SATELITE	12	12	12	12
7.864	JUNTA TORICA D-INT 17,86X2,62	2	2	2	2	439.111.0	PALANCA BLOCAJE DIFERENCIAL	1	1	1	1
7.867	JUNTA TORICA 23,81X2,62	2	2	2	2	439.112.0	PALANCA INTERNA BLOCAJE DIF.	1	1	1	1
7.878	ANILLO TORICO OR-4675 3,53X171	2	2	2	2	439.113.0	DISTANCIADOR	4	4	4	4
7.884	JUNTA TORICA 63,17X2,62	1	1	1	1	439.114.0	PROTECCION	2	2	2	2
7.894	JUNTA TORICA OR 159 55,56X3,53	1	1	1	1	439.116.0	PERNO DE MANDO	1	1	1	1
7.917	ANILLO TORICO OR-4700 3,53X177	1	1	1	1	439.119.0	TIRANTE	1	1	1	1
7.920	JUNTA TOR. OR-3100D-INT25,07X2,6	6	6	6	6	439.121.0	SOPORTE PEDAL ACELERADOR	2	2	2	2
7.929	ENGRASADOR ESFERICO 6-100	1	1	1	1	439.124.0	PERNO PARA GANCHO	1	1	1	1
7.950	EMPURADURA	7	7	7	7	439.200.0	PERNO PARA ACELERADOR	1	1	1	1
7.953	EMPURADURA COLOR ROJO	1	1	1	1	439.201.1	PRIMERA REDUCCION	1	1	1	1
7.967	TAPON VACIADO CABEZA EXAGONAL	3	2	3	2	439.202.1	ENGRANAJE PESCAOLEO	1	1	1	1
7.968	TAPON ROSCADO Ø 3-8" GAS DIN-910	4	4	4	4	439.203.1	EJE ACOPLAMIENTO MOTOR	1	1	1	1
8.024	JAULA ABUJAS K-42X50X18 JM	1	1	1	1	439.211.0	ENGRANAJE INTERMEDIO T.F.	1	1	1	1
8.028	JAULA ABUJAS K-35X42X20	2	2	2	2	439.213.0	ENGRANAJE DESPLAZABLE T.F.	1	1	1	1
8.035	JAULA ABUJAS K20X30X30F	12	12	12	12	439.267.0	PROTECCION DEPOSITO L=1500	3	3	3	3
8.044	CASQUILLO HK-3016	1	1	1	1	439.268.0	CENTRADOR EMBRAGUE	2	2	2	2
8.046	JAULA ABUJAS K-40X45X21	2	2	2	2	439.273.0	CASQUILLO 25X13,2X28	2	2	2	2
8.055	JAULA ABUJAS K-20X28X20	1	1	1	1	440.142.0	DISTANCIADOR	1	1	1	1
8.077	RODAMIENTO DNK 26/20 26X34X20	2	2	2	2	440.143.0	DISTANCIADOR	1	1	1	1
8.088	RODAMIENTO RNA 6902 20X28X23	2	2	2	2	440.154.0	PERNO PARA PALANCA T.F.	1	1	1	1
8.158	BOLA ACERO 5/16"	2	2	2	2	440.179.0	RACORD	1	1	1	1
8.160	BOLA ACERO 3/8"	1	1	1	1	440.202.0	CARTER POSTERIOR	1	1	1	1
8.163	BOLA ACERO 15/32"	1	1	1	1	440.364.5	BUJE ANTERIOR	2	2	2	2
8.242	RODAMIENTO 6014	1	1	1	1	440.364.6	BUJE POSTERIOR	2	2	2	2
8.260	RODAMIENTO 6014-2RS	4	4	4	4	440.365.0	PALIER PORTA-SATELITES	4	4	4	4
8.265	RODAMIENTO 6206	4	4	4	4	440.366.0	CASQUILLO DE CENTRAJE	2	2	2	2
8.266	RODAMIENTO 6207	4	4	4	4	442.515.0	RACORD REDUCCION 1/2" GAS	1	1	4	4
8.292	RODAMIENTO 6206-Z	2	2	2	2	442.516.0	ARANDELA METAL BUNA M-20X1,5	2	2	4	4
8.293	RODAMIENTO 6205-Z	3	3	3	3	442.522.1	TUBO FLEX.L=1150 (RETORNO DIREC	1	1	1	1
8.324	RODAMIENTO 6008 2RS	2	2	2	2	442.526.3	TUBO RETORNO DIRECCION	1	1	2	2
8.330	RODAMIENTO 6202-2RS	1	1	1	1	442.527.0	MACHON 3/8" - 3/8"	1	1	1	1
8.332	RODAMIENTO 6304	1	1	1	1	442.542.0	MACHON RED. 1/2" GAS-3/8" GAS	2	2	1	1
8.333	RODAMIENTO 6305	1	1	1	1	442.544.1	JUNTA QUADRINO 10,77X2,62	1	1	1	1
8.349	RODAMIENTO 6304-2RS	1	1	1	1	442.548.0	TORICO 32,92X3,53 (90 SHORE)	1	1	1	1
8.351	RODAMIENTO 6306-2RS	1	1	1	1	442.555.0	ARANDELA TOPE BRAZOS	1	1	1	1
8.546	RODAMIENTO NJ-206 E	1	1	1	1	442.556.0	ARANDELA TOPE BRAZOS	1	1	1	1
8.547	RODAMIENTO NJ-210	1	1	1	1	442.557.0	RETEN 50X65X8 D.E.	1	1	1	1
8.566	RODAMIENTO 30208	1	1	1	1	442.558.0	RETEN 45X60X8 D.E.	1	1	1	1
8.567	RODAMIENTO 30210	4	4	4	4	442.651.0	REFUERZO CALANDRA ARES	1	1	1	1
8.646	RODAMIENTO 639114.	1	1	1	1	453.522.0	GANCHO ANTERIOR	1	1	1	1
8.692	RODAMIENTO NJ-305	2	2	2	2	453.568.0	PERNO ANTERIOR	1	1	1	1
8.713	RODAMIENTO NJ 2205 E	1	1	1	1	464.114.0	ENGANCHE GRADUABLE	1	1	1	1
9.088	TENSOR CABLE	1	1	1	1	470.330.0	PROTECCION TOMA DE FUERZA	1	1	1	1
9.091	LAMPARA 12V 4W	6	6	6	6	470.393.0	CALANDRA (IMPORTACION)	1	1	1	1
9.097	LAMPARA 12V 21 W	2	2	2	2	493.162.0	CABLE CUENTA VUELTAS	1	1	1	1
9.098	LAMPARA 12V 21 5W	2	2	2	2	493.202.0	EJE CONDUCTOR	1	1	1	1
403199	MOTOR 11 LD 626-3 M-251482	2	2	2	2	493.261.0	GOMA TUBO DIRECCION	1	1	1	1
403502	MOTOR D-303-2 (VERSION 31106)	1	1	1	1	508.008.0	CASQUILLO	1	1	2	2
110.086.0	TERMINAL CON TORNILLO	3	3	3	3	593.107.0	SOMBRERETE	2	2	2	2
110.223.0	ESPARRAGO	8	8	8	8	600.103.1	CARDAN SUPERIOR CORTA GORDA	1	1	1	1
110.379.0	CASQUILLO LLAMADA	1	1	1	1	600.104.1	CARDAN INFERIOR LARGA DELGADA	1	1	1	1
110.421.0	SUJETA CABLE	2	2	2	2	601.127.0	JUNTAS	1	1	1	1
110.561.0	CHAPA CONCAVA CARTER	1	1	1	1	601.217.0	TORNILLO RESPIRADERO	1	1	1	1
124.011.0	DISTANCIADOR	1	1	1	1	601.247.0	TORNILLO ESPECIAL	3	3	3	3
128.036.0	MUELLE 46X12X1,5	1	1	1	1	601.330.0	JUNTA METAL-BUNA M-18X1,5	11	15	9	12
140.102.0	CUENTA VUELTAS	1	1	1	1	601.331.0	TAPON NIVEL ACEITE	2	2	2	2
169.224.0	MUELLE LARGO	3	3	3	3	610.212.0	INTERRUPTOR SEBUD ARRANQUE	1	1	1	1
170.137.0	AVISADOR	1	1	1	1	630.107.0	PASACABLES	2	2	2	2
170.213.0	CONMUTADOR INTERMITENTE	1	1	1	1	631.105.0	DESPLAZABLE	1	1	1	1
170.233.0	ENCHUFE RAPIDO HIDRAULICO	1	1	1	1	631.108.0	ESPESOR PARA BUJE	2	2	2	2
170.364.0	FARO ANTERIOR	2	2	2	2	675.102.0	ATAQUE ANTERIOR	1	1	1	1
170.401.0	PLACA TABLERO INSTRUMENTOS	1	1	1	1	681.106.0	ARANDELA RETENCION	8	8	10	10
263.101.0	ORBITROL 80 + LS	1	1	1	1	886.104.1	DISTANCIADOR	1	1	1	1
402.008.0	CLIP C.L. 4MM	6	6	6	6	886.113.0	CILINDRO DIRECCION	2	2	2	2
409.406.0	CASQUILLO	2	2	2	2	886.117.1	ROTULA M-25X1,5 (ITALIA)	2	2	2	2
410.215.0	BOMBA DE FRENO	1	1	1	1	886.122.0	RACOR	4	4	5	5
439.100.0	CORONA INTERNA BLOCAJE (180)	1	1	1	1	886.137.0	RACORD M-18X1,5	5	5	4	4
439.100.5	CORONA INTERNA (180)	1	1	1	1	886.138.0	TUERCA M-25X150	2	2	2	2
439.101.0	CORONA INTERNA (186)	1	1	1	1	899.330.0	ANILLO ELASTICO	1	1	1	1
439.102.0	TAPA	2	2	2	2	899.402.0	EMBELLECEDOR FAROS	1	1	1	1
		4	4	4	4	899.407.0	PILOTOS-FLECHA IZQ.MT-0001-0030	1	1	1	1
						899.408.0	PILOTOS-FLECHA DCHO.MT0001-0031	1	1	1	1

REFERENCIA - DENOMINACION
CANTIDAD POR MAQUINA

EDICION	Septiembre-98
---------	---------------

TRACTOR 980 ED especial - 980 E3 especial



REFERENCIA	DENOMINACION DE LA PIEZA	981.42	981.	738.42	738.43	REFERENCIA	DENOMINACION D LA PIEZA	981.42	981.43	738.42	738.43
899.415.0	FUSIB.PETACA 30A BUILERA 460130	2	2	2	2	917.239.0	PASADOR EN R				
899.416.0	FUSIB.PETACA 15A BUILERA 460115	2	2	2	2	924.107.0	AMORTIGUADOR	2	2	2	2
899.417.0	FUSIB.PETACA 7,5A BUILERA460107	2	2	2	2	941.208.0	TAPON ORIFICIO CARTER	2	2	2	2
899.451.0	CATADIOPTRICO RINDER-703.02	2	2	2	2	941.209.0	TAPON	1	1	1	1
899.500.1	CARTER ELEVADOR PROFUNDIDAD	1	1	1	1	946.103.0	DISTANCIADOR	1	1	1	1
899.501.1	SOPORTE ENGANCHE TERCER PTO.	1	1	1	1	946.105.0	DESPLAZABLE TOMA DE FUERZA	1	1	1	1
899.502.0	ESPARRAGO ENGANCHE	4	4	4	4	946.109.0	CASQUILLO NB-3030 DO	1	1	1	1
899.503.0	LAHINA DE FLEXION	1	1	1	1	946.110.0	ARANDELA REGLAJE	3	3	3	3
899.504.0	CASQUILLO BALLESTA	1	1	1	1	946.113.0	ARANDELA REGLAJE	3	3	3	3
899.505.0	CASQUILLO TOPE BALLESTA	1	1	1	1	946.114.1	EJE RUEDA CONDUCTOR	1	1	1	1
899.506.1	TORNILLO REGULACION	1	1	1	1	946.117.1	DOBLE ENGRANAJE TOMA DE FUERZA	1	1	1	1
899.507.1	TIRANTE ESFUERZO	1	1	1	1	946.119.0	CONDUCTOR	1	1	1	1
899.508.0	CASQUILLO ARTICULACION	9	9	9	9	946.120.0	CONDUCTOR 2 MARCHA	1	1	1	1
899.509.0	LEVA EXTERNA	1	1	1	1	946.123.1	RUEDA INTERMEDIA TOMA DE FUERZA	1	1	1	1
899.510.1	CASQUILLO ARTICULACION	1	1	1	1	946.124.0	ARANDELA	1	1	1	1
899.511.0	SOPORTE ARTICULACION	1	1	1	1	946.125.0	COLLAR	1	1	1	1
899.512.0	SOPORTE LEVA	1	1	1	1	946.126.0	PASADOR	1	1	1	1
899.513.0	BRUSO BALLESTA	2	2	2	2	946.127.0	SELECTOR CAMBIO	1	1	1	1
899.514.0	DISTRIBUIDOR CONTROL PROF.	1	1	1	1	946.128.0	CHAVETA CAMBIO	1	1	1	1
899.515.0	POMO POSICION AMARILLO	1	1	1	1	946.130.0	ENGRANAJE TOMA DE FUERZA	1	1	1	1
899.516.0	PALANCA POSICION	1	1	1	1	946.136.0	BUJE PARA HORQUILLA	1	1	1	1
899.517.0	POMO DE FIJACION	2	2	2	2	946.137.0	HORQUILLA	2	2	2	2
899.518.0	POMO DE TOPE	1	1	1	1	946.138.0	PERNO	1	1	1	1
899.519.0	POMO ESFUERZO ROJO	1	1	1	1	946.139.0	ESLABON ENLACE	1	1	1	1
899.520.0	PALANCA REFUERZO	1	1	1	1	946.140.0	PERNO	2	2	2	2
899.521.0	TORNILLO TOPE PALANCA	1	1	1	1	946.145.0	PATIN TOMA DE FUERZA	1	1	1	1
899.522.0	CASQUILLO DISTANCIADOR	3	3	3	3	946.146.0	LEVA CON TOMA DE FUERZA	1	1	1	1
899.523.1	EJE MANDO ESFUERZO	1	1	1	1	946.148.0	LEVA INTERNA DEL CAMBIO	1	1	1	1
899.524.0	EJE LEVA	1	1	1	1	946.151.0	JUNTA CARTER CENTRAL POSTERIOR	1	1	1	1
899.525.1	EJE POSICION	1	1	1	1	946.155.0	PASADOR ROSCADO	2	2	2	2
899.526.0	CHAPA DE FRENO	4	4	4	4	946.163.0	MUELLE	1	1	1	1
899.527.0	PLETINA DE FRENO	4	4	4	4	946.164.0	CILINDRO	3	3	3	3
899.528.0	SECTOR DE GRADUACION	1	1	1	1	946.165.0	ARANDELA REGLAJE	3	3	3	3
899.529.0	MUELLE TIRANTE REACCION	1	1	1	1	946.169.0	TORNILLO ESPECIAL	1	1	1	1
899.530.0	TIRANTE LEVA	1	1	1	1	946.171.0	PLAQUITA RETENCION	2	2	2	2
899.531.0	EJE MANDO ESFUERZO	1	1	1	1	946.172.0	JUNTA	2	2	2	2
899.532.0	TUERCA DISPARO RECORRIDO	1	1	1	1	946.173.0	RESPIRADERO ACEITE	1	1	1	1
899.533.0	LEVA DE EQUILIBRIO	2	2	2	2	946.174.0	PLANCHA ROMPE ACEITE	1	1	1	1
899.534.0	RUEDA DE MANDO	2	2	2	2	950.122.0	ARANDELA	2	2	2	2
899.535.0	TIRANTE MANDO POSICION	1	1	1	1	950.404.0	RACOR BOMBA A 2 VIAS	1	1	1	1
899.536.0	TIRANTE MANDO ESFUERZO	1	1	1	1	952.103.0	MUELLE STOP DE SEGURIDAD	1	1	1	1
899.537.0	TIRANTE REACCION	1	1	1	1	956.126.0	PALANCA REDUCTOR	1	1	1	1
899.538.0	LEVA ARTICULACION	1	1	1	1	961.364.0	TAPON	1	1	1	1
899.539.0	EJE ACOPLAMIENTO	1	1	1	1	970.123.1	CORONA DIFERENCIAL	1	1	1	1
899.540.0	EJE CRUCETA	2	2	2	2	970.124.3	EJE CON PIRON	1	1	1	1
899.541.0	EJE DE GUIA	1	1	1	1	970.138.0	PRISIONERO	8	8	8	8
899.542.0	TUBO DISTANCIADOR	1	1	1	1	970.142.0	PATIN	3	3	3	3
899.543.0	LEVA ARTICULACION	2	2	2	2	970.623.5	CARTER CENTRAL ANTERIOR	1	1	1	1
899.544.0	TUBO TOMA AUXILIAR	1	1	1	1	979.088.0	ACELERADOR	1	1	1	1
899.545.0	LEVA INTERNA ESFUERZO	1	1	1	1	979.117.1	SOPORTE PUNTAL	1	1	1	1
899.546.0	TORNILLO PALANCA	2	2	2	2	979.230.0	CRUSCOTTO PARTE SUPERIOR	1	1	1	1
899.547.0	TARJETA DE ALUMINIO	1	1	1	1	979.414.0	BATERIA 92 AH	1	1	1	1
899.549.0	TORNILLO EXAG.M-10	1	1	1	1	979.514.0	ARANDELA DE ESTANQUEIDAD	1	1	1	1
899.558.0	EJE ACOPLAMIENTO	1	1	1	1	980.123.0	EJE MULTIPLICADOR	1	1	1	1
899.633.0	ARANDELA ARTICULACION CARCASA	2	2	2	2	980.124.0	RUEDA MEDIA EJE MULTIPLICADOR	1	1	1	1
899.636.2	SOPORTE ARTICULACION CARCASA	1	1	1	1	980.126.0	RUEDA CONDUCTORA MEDIA	1	1	1	1
899.685.0	TAPON TORNILLO ARTIC.CARCASA	2	2	2	2	980.129.1	EJE ANTERIOR TOMA DE FUERZA	1	1	1	1
899.743.0	HORQUILLA LARGA M-BX32	4	4	4	4	980.142.0	ENGRANAJE DESPLAZABLE	1	1	1	1
899.941.0	CALCA FRONTAL CARCASA	1	1	1	1	980.143.0	RUEDA CONDUCTORA GRANDE	1	1	1	1
899.971.0	CALCA CAJA HERRAMIENTAS	1	1	1	1	980.144.0	EJE INVERTIDOR	1	1	1	1
900.018.0	MUELLE	1	1	1	1	980.145.0	RUEDA CONDUCTORA GRANDE	1	1	1	1
900.028.0	FUELLE GOMA	1	1	1	1	980.146.0	ENGRANAJE 3	1	1	1	1
900.099.0	TAPON GRAFILADO	1	1	1	1	980.150.0	SOPORTE GUARDABARRO DERECHO	1	1	1	1
900.125.0	DISTANCIADOR EN DOS MITADES	1	1	1	1	980.155.0	DISTANCIADOR	1	1	1	1
900.134.0	CAJA DIFERENCIAL	1	1	1	1	980.159.0	LEVA INTERNA CAMBIO	1	1	1	1
900.136.1	PLANETARIO	4	4	4	4	980.160.0	CASQUILLO EMPUJA-DISCO	1	1	1	1
900.137.1	SATELITE	4	4	4	4	980.163.0	HORQUILLA EMBRAGUE	1	1	1	1
900.138.0	PERNO DE SATELITE	4	4	4	4	980.165.0	MUELLE RETROCESO COJINETE	1	1	1	1
900.139.0	CHAPA SEGURO TORNILLO	2	2	2	2	980.167.0	TUBO GUIA COJINETE EMPUJE	1	1	1	1
900.149.0	PERNO	8	8	8	8	980.168.0	SOPORTE COJINETE EMPUJE	1	1	1	1
900.150.0	DISTANCIADOR	1	1	1	1	980.185.2	DEPOSITO DE COMBUSTIBLE	1	1	1	1
900.152.0	PASADOR	2	2	2	2	980.186.A	TAPON DEPOSITO	1	1	1	1
900.172.0	PASACABLE	1	1	1	1	980.186.B	TAPA EMBELLECEDORA	1	1	1	1
901.212.0	MUELLE	1	1	1	1	980.186.C	TAPA PROTECCION	1	1	1	1
901.226.0	ESPESOR LAM.	3	3	3	3	980.187.0	PLAQUITA CARACTERISTICAS 980 ED	1	1	1	1

REFERENCIA - DENOMINACION
CANTIDAD POR MAQUINA

Septiembre-98	EDICION

TRACTOR 980 ED especial - 980 E3 especial



REFERENCIA	DENOMINACION DE LA PIEZA	981.42	981.43	738.42	738.43	REFERENCIA	DENOMINACION DE LA PIEZA	981.42	981.43	738.42	738.43	
980.195.0	DISTANCIADOR SOPORTE BATERIA				2	2	980.570.1	SOPORTE TENSOR	1			
980.206.0	PERNO CENTRAL GRUPO	1	1				980.575.0	TAPON PROTECCION ENCHUFE RAPIDO	1			
980.216.0	SOPORTE DIRECCION	1	1				980.580.0	TAPON CIERRE CILINDRO	1	1		1
980.222.0	CODO TUBO ASPIRACION	1	1		1		980.583.5	TUBO FLEX.L=1000(TL3/8-RC M-14)	1			1
980.238.0	CONJUNTO TUBO DIRECCION	1	1				980.585.0	TUBO GOMA ASPIRACION L=1300	1	1		
980.240.0	BANCHO SUJETACABLES	1	1		1		980.587.0	DISTRIBUIDOR HIDR.MONO-BLOQUE	2	2		2
980.245.0	CABLE FRENO DER.	1	1		1		980.588.0	TUBO RETORNO DISTRIBUIDOR	1			
980.246.0	BALANCIN FRENO	1	1		1		980.589.0	POMO LOBULADO	1			
980.248.0	CASQUILLO POLEA	1	1		1		980.591.0	CADENA CON GRILETE Y BULON	1	1		1
980.250.0	PEDAL ACCELERADOR	1	1		1		980.592.0	TUERCA CENTRAL TENSOR	2	2		2
980.256.0	EJE DE LA DIRECCION	1	1		1		980.593.0	CADENA CON CANCAHO	2	2		2
980.261.0	TUBO DISTR. - PLATO DERECHO	1	1		1		980.594.0	CAJA HERRAMIENTAS IMPORTACION	1	1		1
980.267.0	SOPORTE PORTA FAROS POSTERIOR	2	2		2		980.597.0	SOPORTE DEPOSITO LIQUIDO FRENOS	1	1		1
980.268.0	PASACABLES 12X24X11	1	1		1		980.599.0	RACORD ENTRADA M-14X1,5-3/8" GAS	1	1		1
980.270.0	PASAC.15X7X9 REF.NORVERTO 223	1	1		1		980.654.0	CALCA DIFERENCIAL	1	1		1
980.272.0	SOPORTE DIRECCION	1	1		1		980.613.0	ESCUADRA SOPORTE DISTRIBUIDOR	1	1		1
980.274.0	CABLE FRENO IZQUIERDO	1	1		1		980.667.0	TAMBOR DE FRENO	2	2		2
980.276.0	TORNILLO M-8X16 (DIN-7985)	8	8		8		980.691.0	DISTANCIADOR EXAGONAL			2	2
980.277.0	TORNILLO M-6X12 (DIN-7985)	6	6		6		980.906.0	HORQUILLA SOPORTE CILINDROS	2	2		2
980.278.0	GUARDABARRO TRAS. DERECHO	1	1		1		980.907.0	CASQUILLO DISTANCIADOR	4	4		4
980.279.0	GUARDABARRO TRAS. IZQUIERDO	1	1		1		980.908.0	CABLE ACCELERADOR PIE	1	1		1
980.280.0	TUBO DISTANCIADOR (38X3.2X133)	1	1		1		980.909.0	CABLE SEGURO DE MARCHAS	1	1		1
980.281.0	ARANDELA 38X30X1	1	1		1		980.910.1	CARCASA SUPERIOR	1	1		1
980.326.0	ARANDELA DE DESGASTE	1	1		1		980.911.0	SOPORTE FRENO DE MANO	1	1		1
980.343.1	TAPETA POSTERIOR	1	1		1		980.912.1	CABLE EMBRAGUE	1	1		1
980.344.1	TAPA DE REGISTRO	1	1		1		980.913.0	PEDAL BLOCAJE DIFERENCIAL	1	1		1
980.345.1	DISTANCIADOR	1	1		1		980.914.0	ESPARRAGO M-10X20 (DIN-835) 8.8	4	4		4
980.346.0	JUNTA TAPETA	1	1		1		980.915.1	SOPORTE SALVAMOTOR	1	1		1
980.350.1	CARTER POSTERIOR	1	1		1		980.916.0	CALCA GUARDABARROS TRASEROS	2	2		2
980.355.1	ENGRANAJE TOMA DE FUERZA INF.	1	1		1		980.917.1	CALCA LATERAL DERECHA	1	1		1
980.356.0	ENGRANAJE T.F.SUPERIOR	1	1		1		980.918.1	CALCA LATERAL IZQDA.	1	1		1
980.359.1	EJE SUPERIOR TOMA DE FUERZA	1	1		1		980.919.0	CALCA MODELO - E3			2	2
980.360.1	EJE INFERIOR TOMA DE FUERZA	1	1		1		980.920.0	CALCA MODELO - ED	2	2		
980.361.0	ENGANCHE GRADUABLE	2	2		2		980.922.0	CARCASA SUPERIOR			1	1
980.368.0	BULON LARGO	2	2		2		980.923.0	SALVAMOTOR			1	1
980.369.0	BULON CORTO	2	2		2		980.924.0	SOPORTE	1	1		1
980.379.0	PLACA PORTA-MATRICULA	2	2		2		980.925.0	RACOR TUBO DE ASPIRACION			1	1
980.386.0	ASIENTO	1	1		1		980.926.0	VARILLA SOPORTE CARCASA			1	1
980.390.0	APOYA-MANOS	1	1		1		980.927.0	CASQUILLO 20X9X48			2	2
980.391.0	SOPORTE BARRA TIRO	2	2		2		980.928.0	ESCUADRA 30X30	1	1		1
980.395.0	SOPORTE ASIENTO	1	1		1		980.929.0	TUBO TOMA REMOLQUE	1	1		1
980.397.1	ESPEJO RETROVISOR	1	1		1		980.931.0	CHAPA SOPORTE CAJA FUSIBLES	1	1		1
980.400.0	CABLE MASA AVISADOR	1	1		1		980.932.0	DEDO EMPUJADOR BOMBA FRENO	1	1		1
980.406.0	TERMINAL	2	2		2		981.156.0	SOPORTE GUARDABARRO IZQUIERDO	1	1		1
980.408.0	TESTIGO BATERIA	1	1		1		981.158.0	GUARDABARRO DELANT.(IZQDO-DCHO)	2	2		2
980.409.0	TESTIGO RESERVA CARBURANTE	1	1		1		981.159.1	SOPORTE SELECTOR T.F.	1	1		1
980.440.0	TEMPORIZADOR	1	1		1		981.160.0	SELECTOR TOMA DE FUERZA	1	1		1
980.441.0	LLAVE DE ARRANQUE	1	1		1		981.162.2	SOPORTE IZQUIERDO APOYAPIES	1	1		1
980.442.0	LUZ MATRICULA	1	1		1		981.163.2	SOPORTE DERECHO APOYAPIES	1	1		1
980.443.0	INTERMITENCIA CENTRAL	1	1		1		981.171.2	TORNILLO M-20	4	4		4
980.444.0	PILOTOS TRASEROS	2	2		2		981.175.0	INDICADOR RESERVA CARBURANTE	1	1		1
980.451.0	CAJA FUSIBLES (0003-0054 MT)	1	1		1		981.182.2	SOPORTE GUARDAB. DELANTEROS	1	1		1
980.455.0	SOPORTE CONEXION ELECT. POST.	1	1		1		981.185.0	PALANCA TOMA DE FUERZA	1	1		1
980.456.0	SOPORTE INTERRUPTOR ARRANQUE	1	1		1		981.201.0	VALVULA DANFOSS OSP 80 ON			1	1
980.461.0	CHAPA SOP. CAJA FUSIBLES	1	1		1		981.207.0	TUBO DISTR.- PLATO IZQUIERDO	1	1		1
980.516.0	CASQUILLO	2	2		2		981.210.1	SOPORTE CENTRAL DIRECCION	1	1		1
980.520.0	MUELLE ENGANCHE TIRANTE 3 P.	1	1		1		981.221.1	SOPORTE DEPOSITO Y BATERIA	1	1		1
980.521.0	PLETINA FIJACION PINZA	2	2		2		981.223.0	CALCA CAJETIN MARCHAS	1	1		1
980.544.0	CASQUILLO 12X8.5 L=10.5	1	1		1		981.227.0	APOYO CAJETIN VELOCIDADES	1	1		1
980.545.0	PALANCA ACC. DISTR.HIDRAULICO	1	1		1		981.229.0	SOPORTE RUEDA CON ESPARRAGOS	4	4		4
980.546.0	VARILLA MANDO DISTR.	1	1		1		981.230.0	APOYAPIES DERECHO	1	1		1
980.547.0	ARANDELA 60X18.2 ESP-15	2	2		2		981.232.0	APOYAPIES IZQUIERDO	1	1		1
980.549.0	TAPA DE ASPIRACION	1	1		1		981.233.0	PEDAL DE EMBRAGUE	1	1		1
980.550.0	TENSOR TERCER PUNTO	1	1		1		981.234.0	PEDAL DE FRENO	1	1		1
980.555.0	BRAZO INFERIOR	2	2		2		981.239.1	BULON ARTICUL. PEDALES	4	4		4
980.561.0	CUERPO ELEVADOR	1	1		1		981.309.1	CHAPA UNION	2	2		2
980.562.0	TAPA CUERPO ELEVADOR	1	1		1		981.315.1	ESCUDO PROTECCION TF	1	1		1
980.563.0	EJE ELEVACION	1	1		1		981.333.1	SOPORTE IZQDO ARCO	1	1		1
980.564.0	CONJUNTO TUBO TAPETA	1	1		1		981.334.1	SOPORTE DER. ARCO	1	1		1
980.565.0	VASTAGO CILINDRO	1	1		1		981.335.1	CJTO. ARCO SEGURIDAD	1	1		1
980.566.0	BIELA INTERIOR	1	1		1		981.338.0	SOPORTE GUARD. TRAS.	1	1		1
980.567.0	PISTON CILINDRO	1	1		1		981.361.0	EJE CON PIRON	1	1		1
980.567.0	BRAZO ELEVACION RECTO	1	1		1		981.418.0	SOPORTE CAJA FUSIBLES	1	1		1
980.568.0	CUERPO CIERRE CILINDRO	2	2		2		981.420.0	CABLE SOPORTE FRONTAL	1	1		1
980.569.0	JUNTA TAPA ELEVADOR	1	1		1		982.150.0	CALCA VELOCIDADES	2	2		2

REFERENCIA - DENOMINACION
CANTIDAD POR MAQUINA

EDICION
Septiembre-98

TRACTOR 980 ED especial - 980 E3 especial



REFERENCIA	DENOMINACION DE LA PIEZA	981.42	981.	738.42	738.43	REFERENCIA	DENOMINACION D. LA PIEZA	981.42	981.43	738.42	738.43
982.152.1	TAPA EMBELLECEDORA	1	1	1	1	983.527.0	BOMBA HIDRAULICA 13 L.				
982.154.0	TAPA CIERRE DER. SOP.DIRCC.	1	1	1	1	983.530.0	TUBO DE RETORNO DEPOSITO				
982.155.0	TAPA CIERRE IZQDA SOP.DIRCC.	1	1	1	1	983.535.0	CONJUNTO PLETINA SUJECION TUBOS				
982.169.1	TENSOR	2	2	2	2	983.537.0	PALANCA FRENO DE MANO	1	1		
982.170.1	HORQUILLA CORTA	2	2	2	2	983.538.5	TUBO RET. DIRECC-CONTROL PROF.	1	1	1	1
982.171.1	HORQUILLA LARGA CON PERNO	2	2	2	2	983.539.0	ORIENTABLE ROSCADO 3/8" GAS	3	3	4	4
982.177.0	TABIQUE SEPARADOR CALOR	2	2	2	2	983.541.0	BRIDA MIKALOR 12-13	2	2	2	2
982.178.1	ESCUADRA TABIQUE	1	1	1	1	983.546.0	MACHON M-14X1,5 - 3/8"	2	2		
982.179.0	PALANCA TOMA DE FUERZA	1	1	1	1	983.549.0	TUBO FLEX.L=1150 (OR-3/8-OR.M-1	1	1		
982.181.0	SOPORTE COJINETE DE EMPUJE	1	1	1	1	983.550.0	REMACHE POP 3,2X7,8 AD-44 STARR	1	1		
982.187.0	CALCA ARRANQUE	1	1	1	1	983.553.0	RACOR EN T (3/8) T/L CENTRAL	1	1		
982.189.0	CALCA TOMA DE FUERZA	1	1	1	1	983.554.0	TUBO FLEX.L=250 (2 T/L-3/8)	1	1		
982.201.0	TORNILLO M-14X1,5X35 DIN 933	1	1	1	1	983.555.0	T.FLEX.L=320(T/L.3/8-OR.14)	1	1		
982.206.0	TORNILLO 3,5X13 DIN 7983	2	2	2	2	983.565.0	TUBO FLEX.LS-ELEV (C/CODO.3/8)	1	1		
982.207.0	TORNILLO 5X25 DIN 931	2	2	2	2	983.566.0	TUBO PRES.L=1300 (2 TL-3/8)	1	1		
982.208.0	ANILLO ELASTICO 6 DIN 6799	5	5	5	5	983.756.0	TORNILLO FIJACION PALANCA	1	1	1	1
982.209.0	ANILLO ELASTICO 4 DIN 6799	1	1	1	1	983.902.0	CABLE SOPORTE CARCASA	1	1	1	1
982.210.0	TORNILLO 5X12 DIN 965	2	2	2	2	983.926.0	CABLE EMBRAGUE	1	1		
982.211.0	MUELLE DE PLATILLO 6 DIN 2093-B	2	2	2	2	983.929.1	FIELTRO BATERIA 280X183X6-10	2	2	2	2
982.212.0	TORNILLO 6X45 DIN 912	6	6	6	6	983.931.1	PRENSA EMBRAGUE P&V 17.117			1	1
982.225.0	PAS.ELAST.ESPIRAL 5X22 DIN 7343	2	2	2	2	983.932.0	DISCO EMBRAGUE #215 P&V			1	2
982.560.0	ARANDELA GOMA 20X9X4	4	4	4	4	983.937.0	LLAVE FIJA 17/19	1	1	1	1
982.700.0	TOPE	4	4	4	4	983.945.0	LLAVE ALLEN DE 6	1	1	1	1
982.909.0	CALCA LOGOTIPO (CAJA HERRAM.)	3	3	3	3	983.955.0	LLAVE DE TUBO DE 13	1	1	1	1
982.911.0	PLAQUITA CARACTERISTICAS	1	1	1	1	983.956.0	LLAVE FIJA 8/9	1	1	1	1
982.912.0	RETEN 12X22X6 (129) REF.90-005	1	1	1	1	983.976.0	PASADOR DE ANILLA (-4,5)	1	1	1	1
982.916.0	RETEN 33X50X8	1	1	1	1	983.992.0	MUELLE SUJECION BARRAS	2	2	2	2
982.917.0	TORNILLO M-14X25 (DIN-912)	1	1	1	1	983.994.0	ARANDELA DE COBRE 16X8X1,5	1	1	1	1
982.927.0	TORNILLO M-16X30X1,5 DIN 912	2	2	2	2	983.995.0	TORNILLO M-8X25 DIN 603	4	4	4	4
982.940.0	TORNILLO M-14X75 DIN 931	4	4	4	4	984.502.1	ESPARRAGO RUEDA	24	24	24	24
982.942.0	TUERCA AUTOBLOCANTE M-14	2	2	2	2	984.503.0	TORNILLO GUIA	1	1	1	1
982.946.0	PLAQUITA CARACT. (ARCO)	2	2	2	2	984.508.0	VARILLA ROSC.AM10X16 DIN915-125	1	1	1	1
982.952.0	ANILLO TORICO OR 32X3	1	1	1	1	984.512.0	TORNILLO 10X12 DIN 933	1	1	1	1
982.959.0	TORNILLO M-14X90 DIN-931	2	2	2	2	984.520.0	AMORTIZADOR CON CARA ROSCADA	2	2	2	2
982.960.0	TUERCA M-14 AUT.ALTA (DIN-1567)	2	2	2	2	984.528.0	TUERCA ALHEN. M-24X1,5 DIN 937	5	5	5	5
982.962.0	TERMINAL DESNUDO	2	2	2	2	984.529.0	TORNILLO M-10X35 DIN-6912	4	4	4	4
982.963.0	TERMINAL DESNUDO	10	10	10	10	984.536.0	TUERCA M-22X2,5	2	2	2	2
982.964.0	FUNDA AISLANTE	4	4	4	4	984.542.0	TORNILLO M6X30 DIN 931	2	2	2	2
982.965.0	TERMINAL DESNUDO	10	10	10	10	984.550.0	REMACHE PISTOLA D-4,8X10,5	19	19	19	19
982.988.0	TUERCA AUTOBL. M-4 (DIN-985)8.8	4	4	4	4	984.560.0	TORNILLO M-12X80 DIN 931	2	2	2	2
982.989.0	TORNILLO M-4X50 (DIN-912)	2	2	2	2	984.562.0	TUERCA AUTOBLOC. M-16 DIN 985	1	1	1	1
982.993.0	TORICO 53.57X3.53	2	2	2	2	984.567.0	TAPON M-10/100 CONICO	1	1	1	1
982.994.0	RASCADOR 45X53.6X5.3	2	2	2	2	984.569.0	TORNILLO M-8 X 65 DIN-912	3	3	3	3
982.995.0	COLLARIN TS/L 45/53/8	2	2	2	2	984.589.0	TORNILLO M-14X30X1,5 DIN 912	4	4	4	4
982.996.0	ANILLO SEGURIDAD INT.D-42X2.5	2	2	2	2	984.595.0	TAPON EXAGONAL M-18X1,5	3	3	3	3
982.999.0	TAPON ROSCADO 8-3/8" DIN-910	2	2	2	2	984.599.0	TORNILLO ORIENTABLE 3/8" GAS	1	1	1	1
983.101.0	EJE ACOPLAMIENTO MOTOR	1	1	1	1	984.603.0	PASADOR DE ANILLA D8	3	3	3	3
983.105.0	CENTRADOR EMBRAGUE	2	2	2	2	984.608.0	ARANDELA D-10 DIN-7980	4	4	4	4
983.106.0	EJE SATELITE	12	12	12	12	984.609.0	ARAND.DENT.EXT.10,5 DIN-6798	12	12	12	12
983.107.1	ENGRANAJE ACCIONAMIENTO BOMBA	1	1	1	1	984.622.0	ARANDELA 68X79X0,10	1	1	1	1
983.108.1	TAPA SOPORTE BOMBA	1	1	1	1	984.623.0	ARANDELA 68X79X0,20	1	1	1	1
983.134.1	PRENSA EMBRAGUE "215" S/PLANO	1	1	1	1	984.624.0	ARANDELA 76X90X0,24	1	1	1	1
983.135.0	DISCO EMBRAGUE 215	1	1	1	1	984.625.0	ARANDELA 76X71X0,2	1	1	1	1
983.145.0	RACOR ORIENTABLE	1	1	1	1	984.626.0	ARANDELA 52X61,5X0,3	1	1	1	1
983.168.0	PAS.DCHO.ANCLAJE GUARDB.DELANT.	1	1	1	1	984.627.0	ARANDELA 52X61,5X0,21	1	1	1	1
983.169.0	PAS.IZQDD.ANCLAJE GUARDB.DEL.	1	1	1	1	984.628.0	ARANDELA 52X61,5X0,17	1	1	1	1
983.173.1	SOPORTE TOPE DE FUNDA	1	1	1	1	984.629.0	ARANDELA 52X61,5X0,5	2	2	2	2
983.179.0	PLANCHAS SELECTORA T.F.	1	1	1	1	984.630.0	ARANDELA 43X50X0,1	1	1	1	1
983.187.1	DEPOSITO HIDRAULICO DIRECCION	1	1	1	1	984.631.0	ARANDELA 43X50X0,3	1	1	1	1
983.188.0	PLETINA SUJECION BATERIA	2	2	2	2	984.632.0	ARANDELA 35X49	1	1	1	1
983.189.0	PLETINA SOPORTE TUBOS	2	2	2	2	984.633.0	ARANDELA 35,25X49X0,30	1	1	1	1
983.190.0	ESCUADRA SOPORTE TUBOS	1	1	1	1	984.634.0	ARANDELA 35,25X49X0,5	1	1	1	1
983.197.1	PALANCA EMBRAGUE	1	1	1	1	984.635.0	ARANDELA 62X71X0,1	1	1	1	1
983.220.0	HANETA CARCASA	1	1	1	1	984.638.0	PASADOR	1	1	1	1
983.402.0	CABLEADO POSTERIOR	1	1	1	1	984.639.0	SEEBER A-20X1,75 S000 DIN-471 B	12	12	12	12
983.403.0	CABLE NEGATIVO DE BATERIA	1	1	1	1	984.640.0	ARANDELA	12	12	12	12
983.404.0	KIT DE CABLES SIMPLES	1	1	1	1	984.647.0	ARANDELA BELLEVILLE 18X35X1,25	12	12	12	12
983.407.0	INTERRUPTOR HIDRAULICO STOP	1	1	1	1	984.654.0	TUERCA M-12 AUTOB.NYLON DIN 985	1	1	1	1
983.408.1	RACOR EMPALME FASTON	1	1	1	1	984.695.0	ARANDELA COBRE D-12X16X1,5	4	4	4	4
983.413.0	LAMPARA FARO ANT.12V 45/40W	1	1	1	1	984.697.0	ARANDELA DENTADO EXTERIOR	4	4	4	4
983.415.0	TUERCA M-5 DIN 985	2	2	2	2	984.707.0	RETEN APOYO ROTOR (40X56X8)	1	1	1	1
983.419.0	CABLEADO FRONTAL	1	1	1	1	984.708.0	BRIDA MIKALOR 9,5-10	2	2	2	2
983.521.1	TUBO 3/8 L=540 OR.14-3/8 R-1	1	1	1	1	984.710.0	DEPOSITO LIQUIDO FRENO	1	1	1	1
983.524.0	TUBO BOMBA A PRESION	1	1	1	1						
983.525.0	TUBO DE PRESION	1	1	1	1						

REFERENCIA - DENOMINACION
CANTIDAD POR MAQUINA

Septiembre-98	EDICION

TRACTOR 980 ED especial - 980 E3 especial



REFERENCIA	DENOMINACION DE LA PIEZA	981.42	981.43	738.42	738.43	REFERENCIA	DENOMINACION DE LA PIEZA	981.42	981.43	738.42	738.43
984.714.0	ARANDELA D-10X14X1	1	1	1	1	986.638.0	TIRANTE	1	1	1	1
984.715.0	ANILLO TORICO 7,5X2,5	1	1	1	1	986.639.0	TIRANTE ROSCADO	1	1	1	1
984.720.0	BRIDA AISLADA 06 (NEGRA)	1	1	1	1	986.642.0	PLETINA ATAQUE GANCHO (ITALIA)	2	2	2	2
984.721.0	TUBO RETORNO GASOIL (L=600)	1	1	1	1	986.657.0	POMO (ITALIA)	2	2	2	2
984.750.0	BRIDA NEGRA 94,5X2,5 (UNEX)	10	10	10	10	988.124.0	ASTA GUIA	1	1	1	1
984.777.0	ANILLO TORICO 69,52 X 2,62	1	1	1	1	988.261.0	MUELLE TOMA DE FUERZA	1	1	1	1
984.780.0	COLLARIN POLIURETANO 90X75X12	1	1	1	1	988.262.0	CASQUILLO	1	1	1	1
984.781.0	JUNTA TORICA OR 39,69X3X53	1	1	1	1	988.327.0	ARANDELA ROZAMIENTO	1	1	1	1
984.785.0	JUNTA TORICA OR 7,66X1,78	1	1	1	1	988.370.0	MUELLE	1	1	1	1
984.788.0	JUNTA	1	1	1	1	988.522.0	PERNO	1	1	1	1
984.798.0	JUNTA TORICA OR-18,57X1,78	1	3	1	3	993.114.0	MUELLE STOP	1	1	1	1
984.805.0	RODAMIENTO 16005	2	2	2	2	993.120.0	AMORTIZADOR CON CARA ROSCADA	1	1	1	1
984.806.0	RODAMIENTO NJ 304E	1	1	1	1	993.121.0	TAPON DESCOMPRESION	2	2	2	2
984.833.0	RODAMIENTO 63002-2RS	1	1	1	1	993.130.0	MUELLE	3	3	3	3
984.841.0	RODAMIENTO 6206 N	1	1	1	1	993.130.0	MUELLE	1	1	1	1
984.842.0	RODAMIENTO 6305 N	1	1	1	1	993.133.0	SECTOR PARA CAMBIO	1	1	1	1
984.848.1	CASQUILLO DU 50/50 P10	1	1	1	1	993.135.0	SELECTOR	1	1	1	1
984.849.0	CASQUILLO DU 45/50 P10	1	1	1	1	993.136.0	TERMINAL	1	1	1	1
984.872.0	ARANDELA DENTADA EXT.M-80IN6798	1	1	1	1	993.144.5	TESTIGO PRESION ACEITE	2	2	2	2
984.873.0	ARANDELA DENTADA EXTERIOR M-4	5	5	5	5	993.144.6	TESTIGO INTERMITENTE	1	1	1	1
984.874.0	TAPON OBTURADOR 1/4" GAS	4	4	4	4	993.145.A	HANDBO COMPUTADOR	1	1	1	1
984.875.0	TAPON OBTURADOR 1/2" GAS	1	1	1	1	993.145.B	TORNILLO 4X12 DIN-7988	1	1	1	1
984.903.0	TUBO PLASTICO	1	1	1	1	993.145.5	COMPUTADOR LUCES	1	1	1	1
984.904.0	PORTAZAPATAS COMPLETO	1	1	1	1	996.427.1	BRIDA PLASTICO	3	3	3	3
984.905.0	PORTAZAPATAS COMPLETO	1	1	1	1	996.503.0	RACORD EN CTO 9965190	1	1	1	1
984.916.0	TERMINAL TOPE FUNDA	1	1	1	1	996.504.0	RACORD SALIDA BOMBA 996502	1	1	1	1
984.923.0	TAPON OBTURADOR 3/8" GAS	1	1	1	1	996.509.0	RACORD 3/8"	1	1	1	1
984.929.0	SENSOR	1	2	1	2	996.510.1	JUNTA METAL BUNA 3/8	2	2	4	2
984.930.0	CABLE CON FUNDA STOP CON TIRADO	1	1	1	1	996.513.6	TAPA	7	7	10	10
984.934.0	LIQUIDO FRENO	1	1	1	1	996.518.0	RACORD ORIENTABLE	1	1	1	1
984.935.0	CUENTA-HORAS ELECTRICO	1	1	1	1	996.519.0	CASQUILLO CTO-9865190	1	1	1	1
984.942.0	TERMINAL APOYO CABLE D 4	1	1	1	1	996.520.0	FILTRO ACEITE	1	1	2	2
984.966.0	CABLE CON FUNDA ACELERADOR	1	1	1	1	996.521.0	ABRAZADERA 20/32	4	4	4	4
984.995.0	CASQUILLO PAPI620 P10 16X18X20	2	2	2	2	997.150.1	TUBO BOMA GAS-OLEO	1	1	1	1
985.133.0	MUELLE TOMA DE FUERZA	1	1	1	1						
985.134.0	MUELLE	1	1	1	1						
985.207.0	CASQUILLO ESTRIADO	1	1	1	1						
985.215.0	ENSANCHE POSTERIOR	2	2	2	2						
985.232.0	CARTER PROTECCION	1	1	1	1						
985.233.0	VOLANTE	1	1	1	1						
985.239.0	PROTECCION	5	5	5	5						
985.240.0	ESPESOR	2	2	2	2						
985.409.5	TOMA CORRIENTE	1	1	1	1						
985.515.6	CONJ. TAPON	1	1	2	2						
986.107.1	EJE TOMA DE FUERZA	1	1	1	1						
986.144.0	TUBO RESPIRADERO	1	1	1	1						
986.201.0	EJE SUPERIOR	1	1	1	1						
986.204.0	ESPARRAGO	2	2	2	2						
986.221.1	CASQUILLO NYLATRON	1	1	1	1						
986.224.0	BULON	2	2	2	2						
986.301.1	CARTER ANTERIOR	1	1	1	1						
986.303.1	RUEDA DE SINCRONIZACION	1	1	1	1						
986.304.0	PERNO	1	1	1	1						
986.311.0	ASTA DE GUIA	1	1	1	1						
986.312.0	BUJE PARA HORQUILLA	1	1	1	1						
986.313.0	PERNO	1	1	1	1						
986.315.0	LEVA INTERMEDIA TOMA DE FUERZA	1	1	1	1						
986.316.5	ARANDELA (50X33,2X1,5)	1	1	1	1						
986.317.0	TORNILLO ESPECIAL	1	1	1	1						
986.321.0	CALCA ADHESIVA T.F.POSTERIOR	1	1	1	1						
986.329.0	CAJA DIFERENCIAL	1	1	1	1						
986.331.0	CASQUILLO DE CENTRAJE	1	1	1	1						
986.400.0	CABLE CONEXION POSITIVO	1	1	1	1						
986.408.6	CABLEADO CENTRAL TRACTOR	1	1	1	1						
986.410.0	TUBO D-10	1	1	1	1						
986.410.1	CONEXION MASA FRONTAL	1	1	1	1						
986.519.1	BOMBA COMPLETA	1	1	1	1						
986.520.0	RACORD	1	1	1	1						
986.602.0	TABLERO INFERIOR	1	1	1	1						
986.613.0	CAJETIN PALANCAS	1	1	1	1						
986.617.0	SOPORTE GANCHO	2	2	2	2						
986.618.6	SOPORTE TIRAD. CIERRE CARCASA	2	2	2	2						
986.621.0	GANCHO PARA CARCASA (ITALIA)	2	2	2	2						
986.631.0	PALANCA CAMBIO	1	1	1	1						
986.635.0	LEVA REDUCTOR	1	1	1	1						

REFERENCIA - DENOMINACION
CANTIDAD POR MAQUINA

	EDICION
Septiembre-98	