

TRACTOR TIPO 996

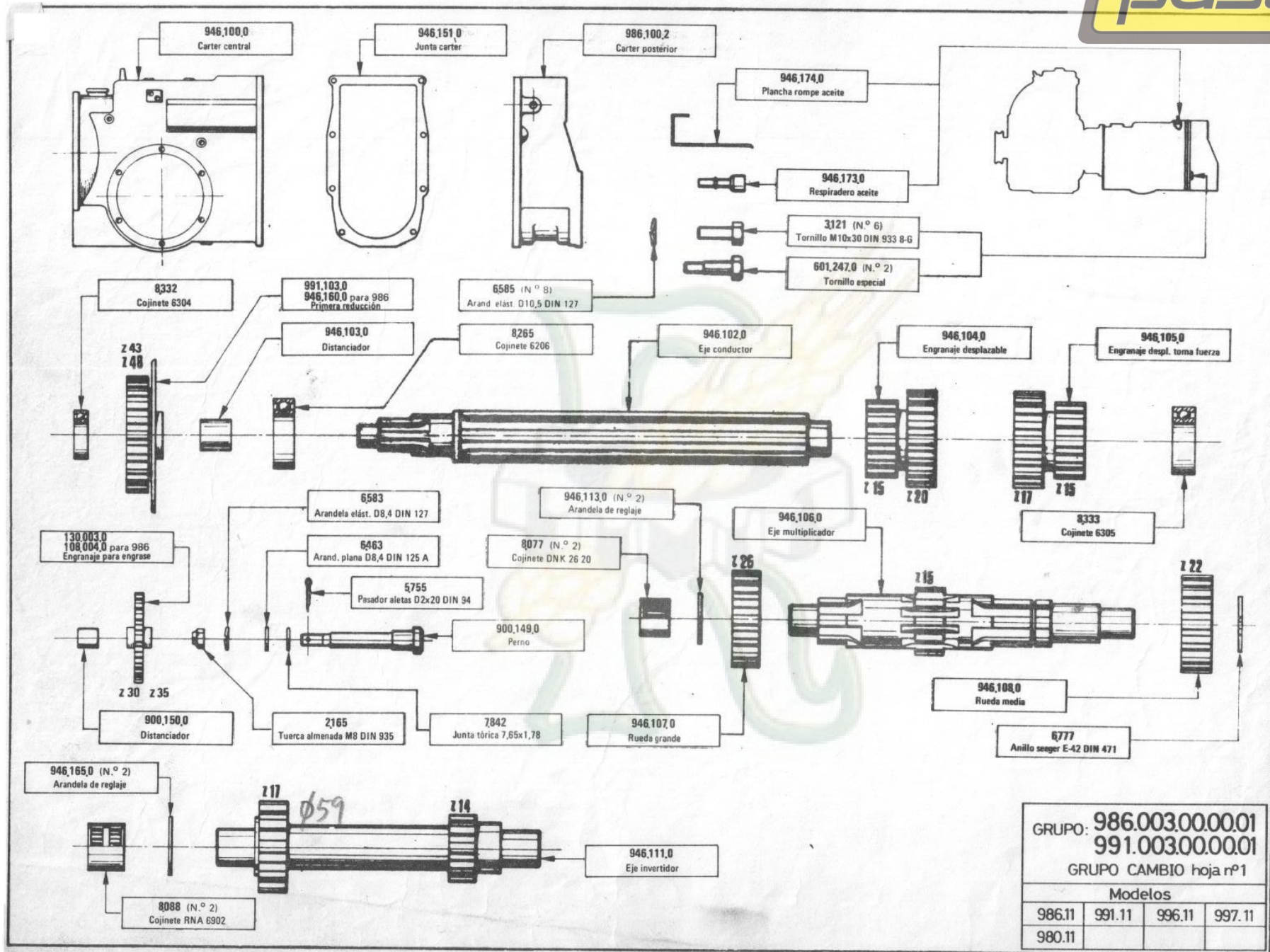

GRUPO: 986.003.00.00.01
991.003.00.00.01
GRUPO CAMBIO hoja nº1

Modelos			
986.11	991.11	996.11	997.11
980.11			

TRACTOR TIPO 996

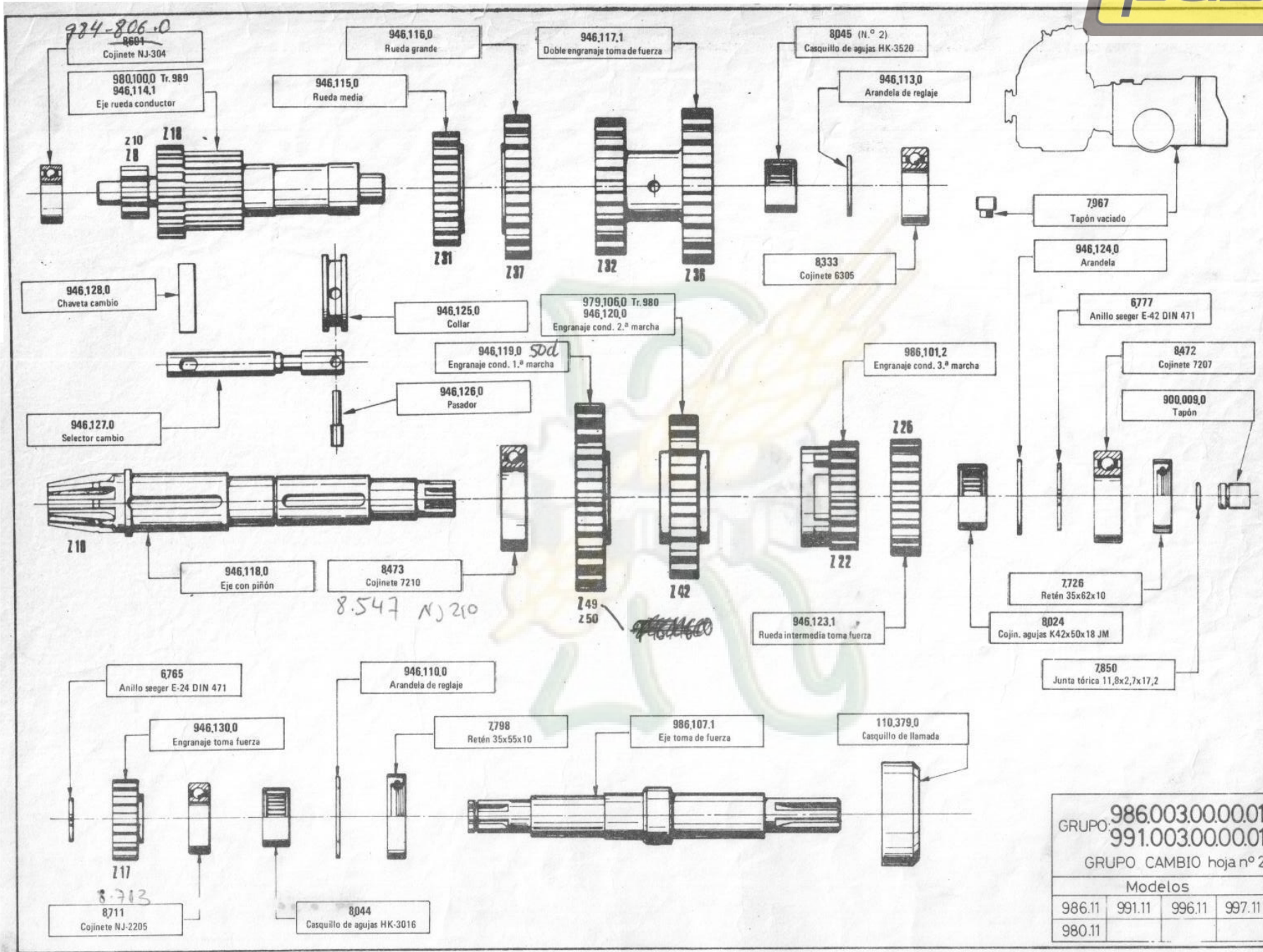

GRUPO:	986.003.00.00.01
	991.003.00.00.01
	GRUPO CAMBIO hoja n° 2
Modelos	
986.11	991.11
986.11	997.11
980.11	

JUNIO 81	EDICION
----------	---------

TRACTOR TIPO 996

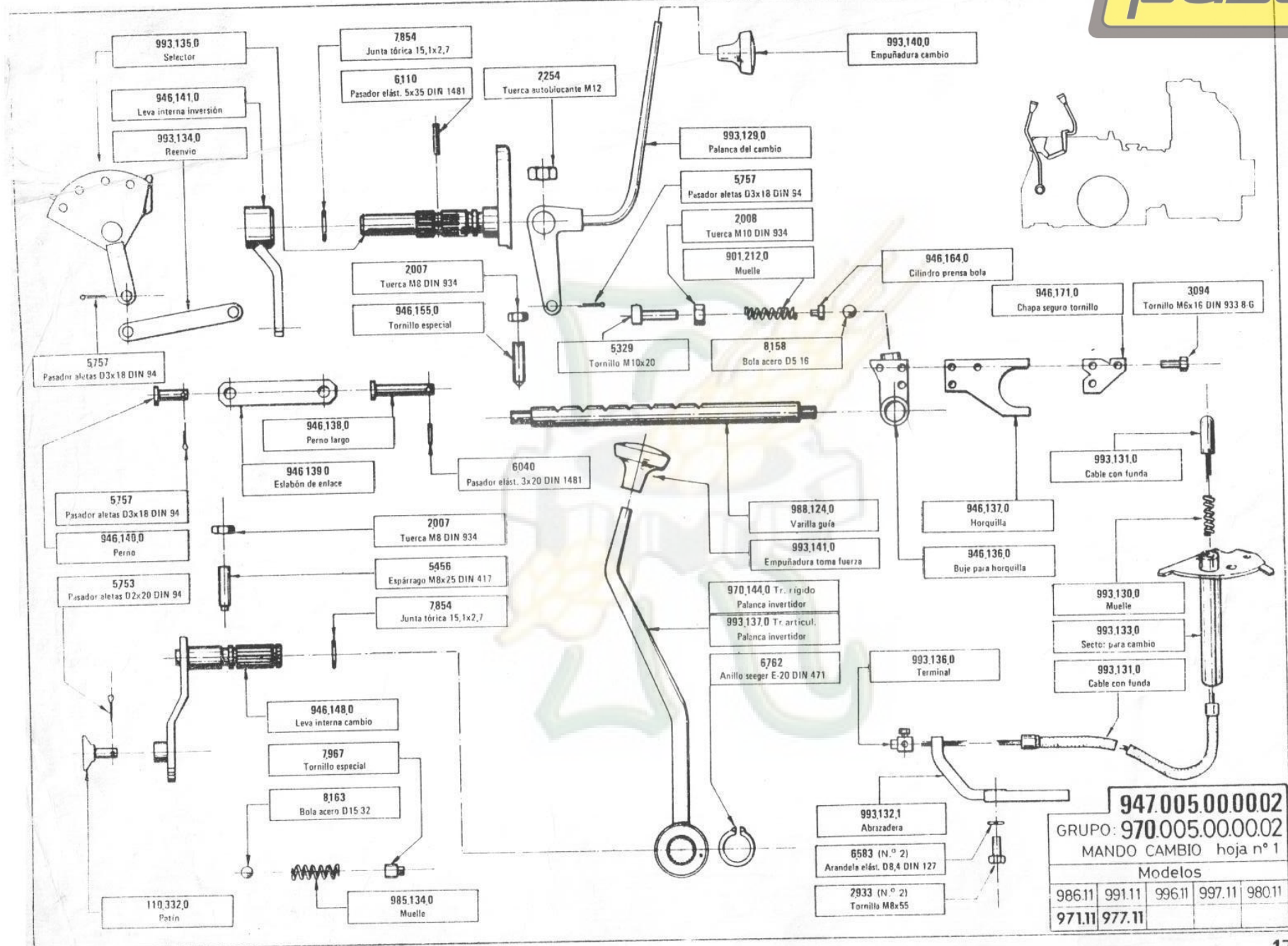

947.005.00.0002
 GRUPO: 970.005.00.0002
 MANDO CAMBIO hoja nº 1

Modelos				
986.11	991.11	996.11	997.11	980.11
971.11	977.11			

JUNIO 81
EDICION

TRACTOR TIPO 996

pasquali

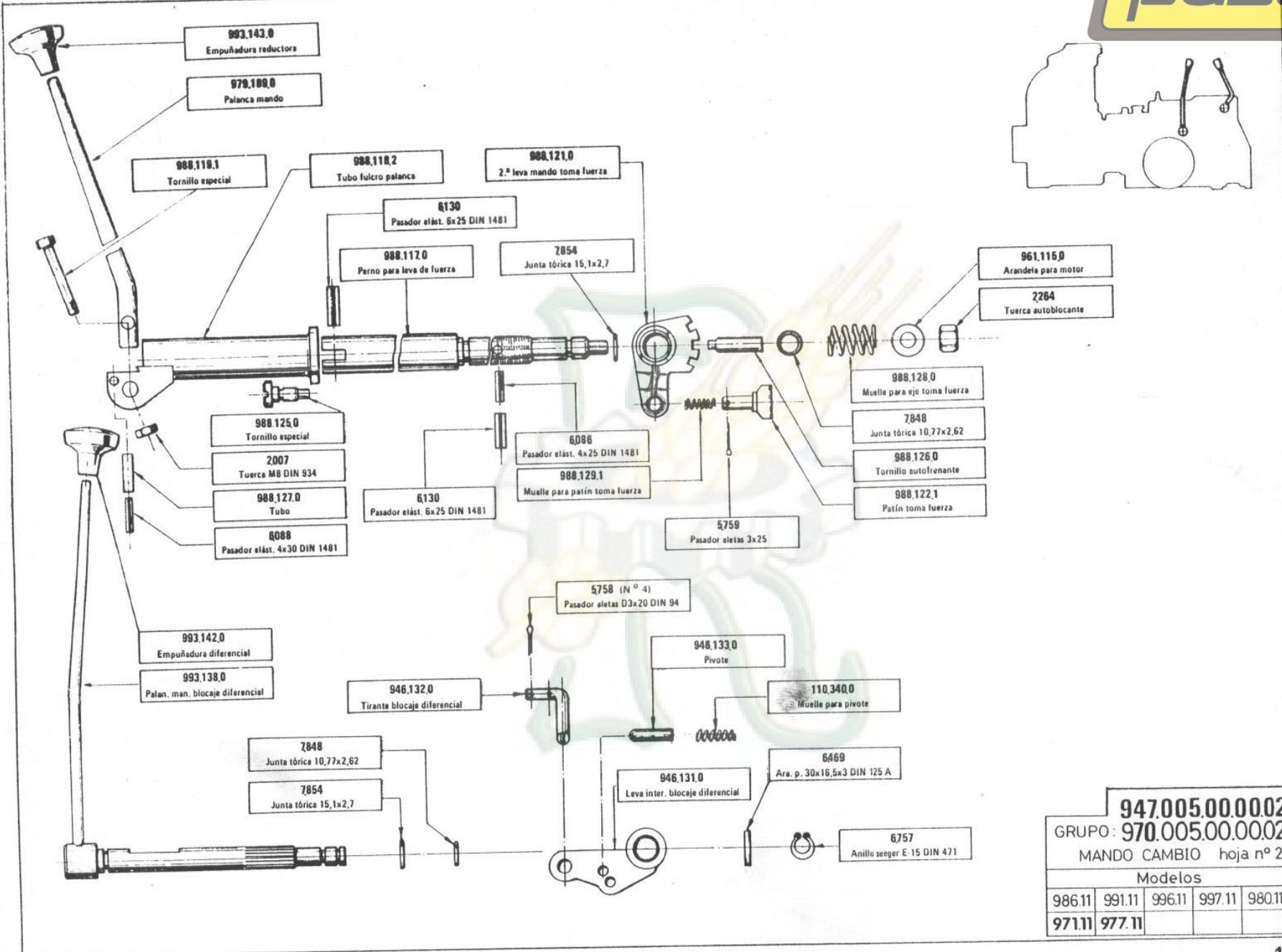
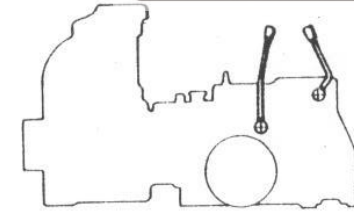

947.005.00.0002
 GRUPO: **970.005.00.0002**
 MANDO CAMBIO hoja nº 2

Modelos

986.11	991.11	996.11	997.11	980.11
971.11	977.11			

18 OING

TRACTOR TIPO 996

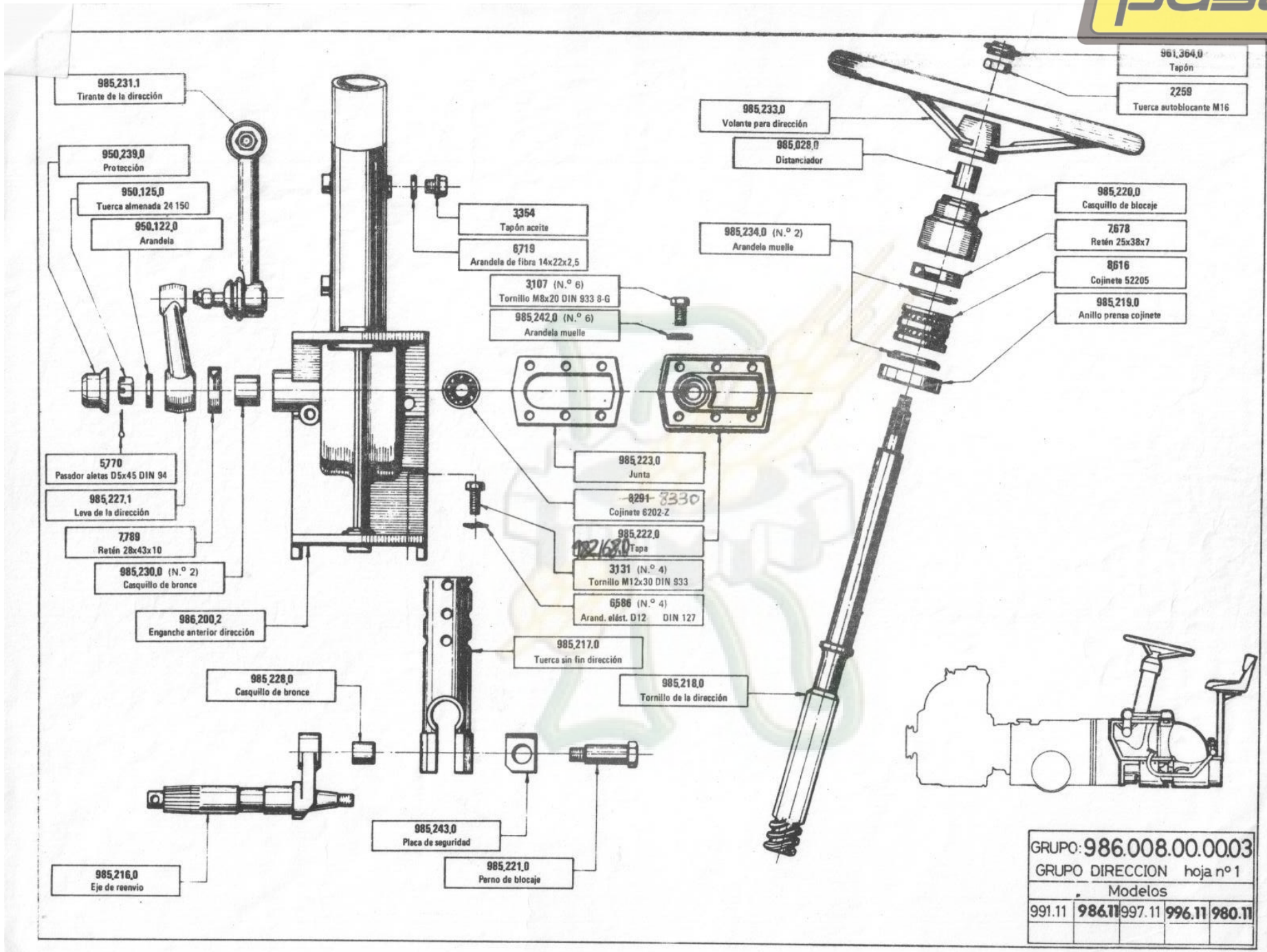

GRUPO: 986.008.00.0003			
GRUPO DIRECCION hoja nº 1			
Modelos			
991.11	986.11	997.11	996.11 980.11

JUNIO 81	EDICION

TRACTOR TIPO 996

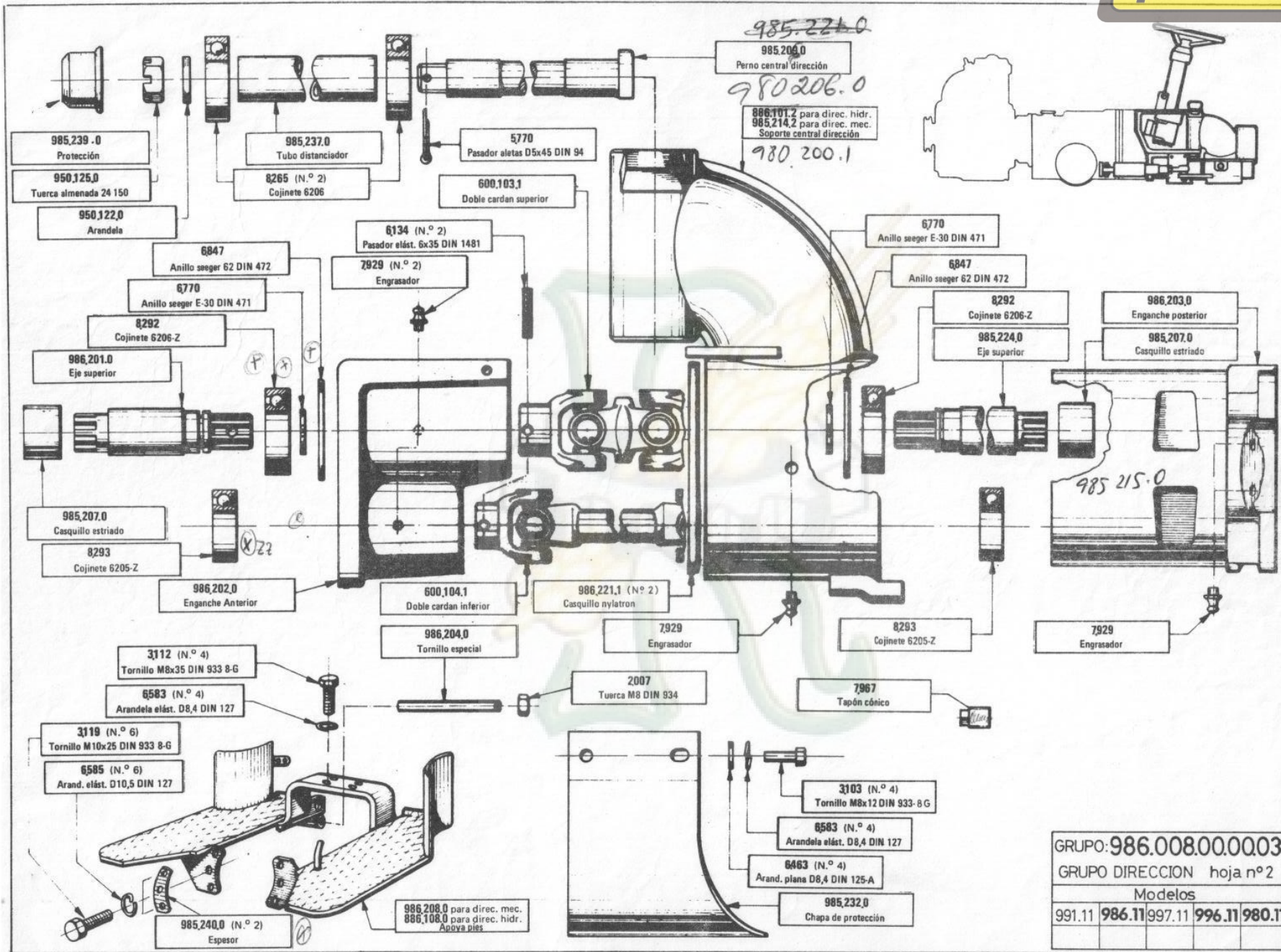

GRUPO: 986.008.00.0003			
GRUPO DIRECCION hoja nº2			
Modelos			
991.11	986.11	997.11	996.11 980.11

JUNIO 81

TRACTOR TIPO 996

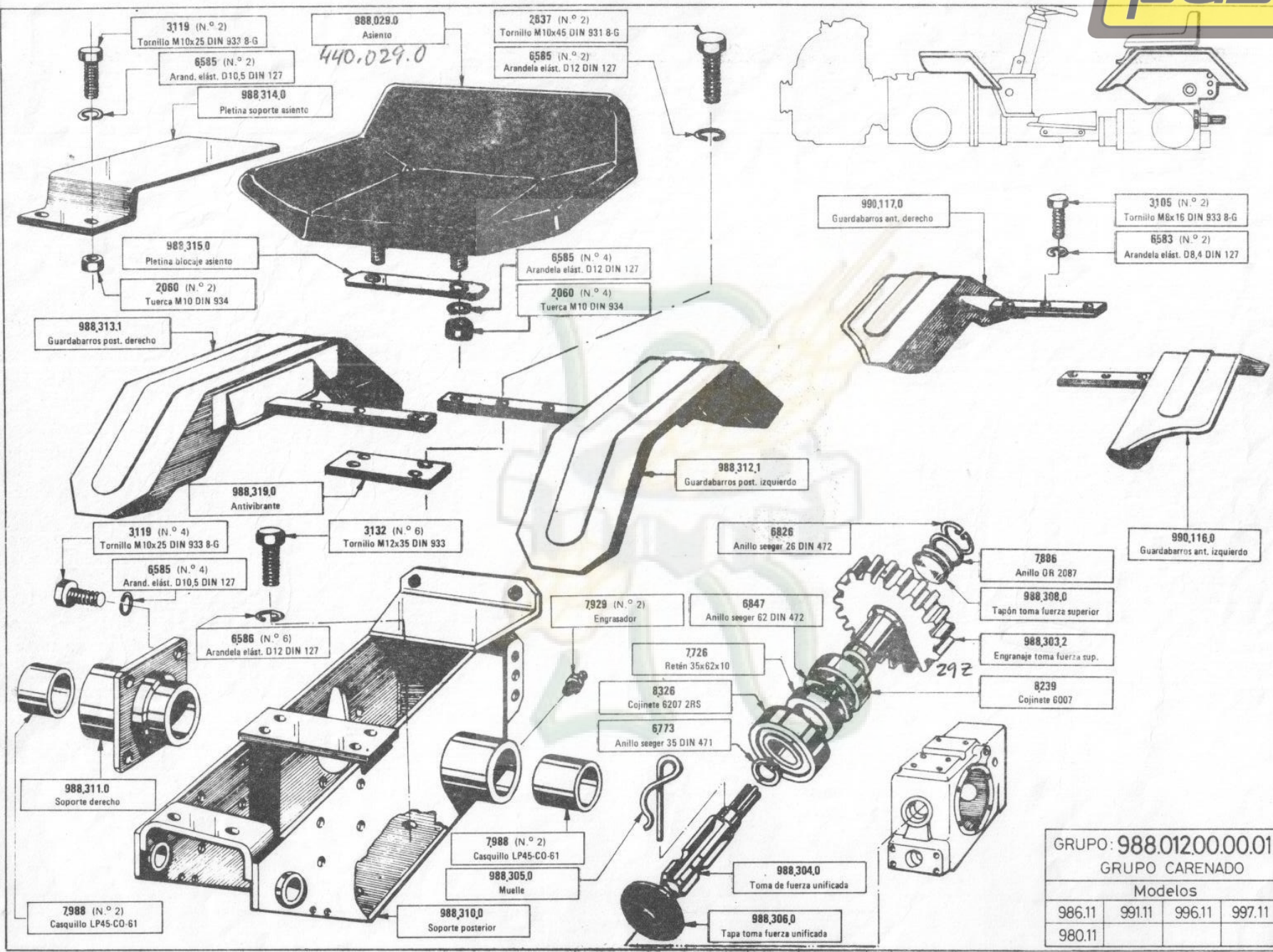

GRUPO: 988.01200.00.01
GRUPO CARENADO

Modelos		
986.11	991.11	997.11
980.11		

JUNIO 81
EDICION

TRACTOR TIPO 996

pasquali

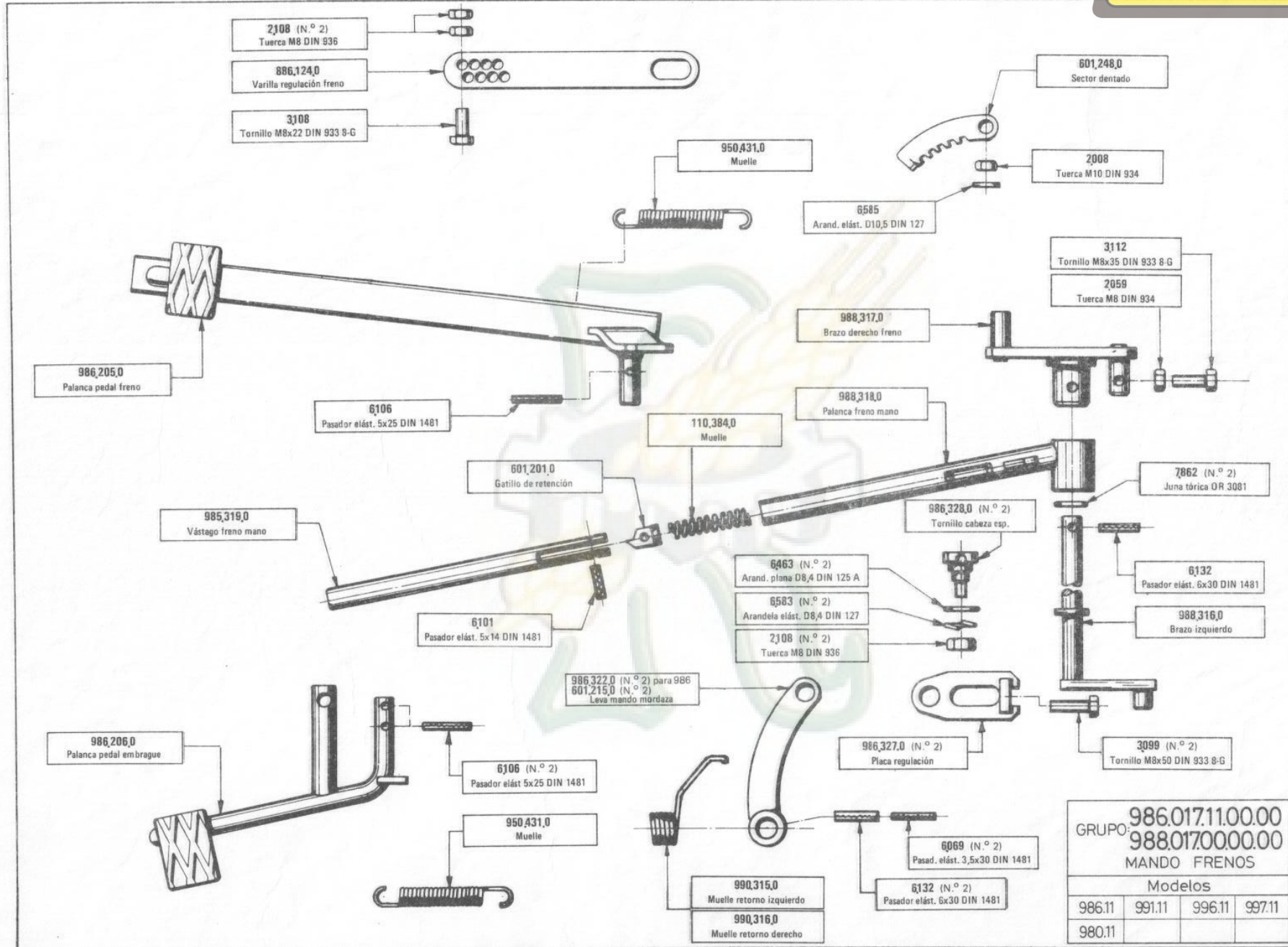

JUNIO 81

EDICION

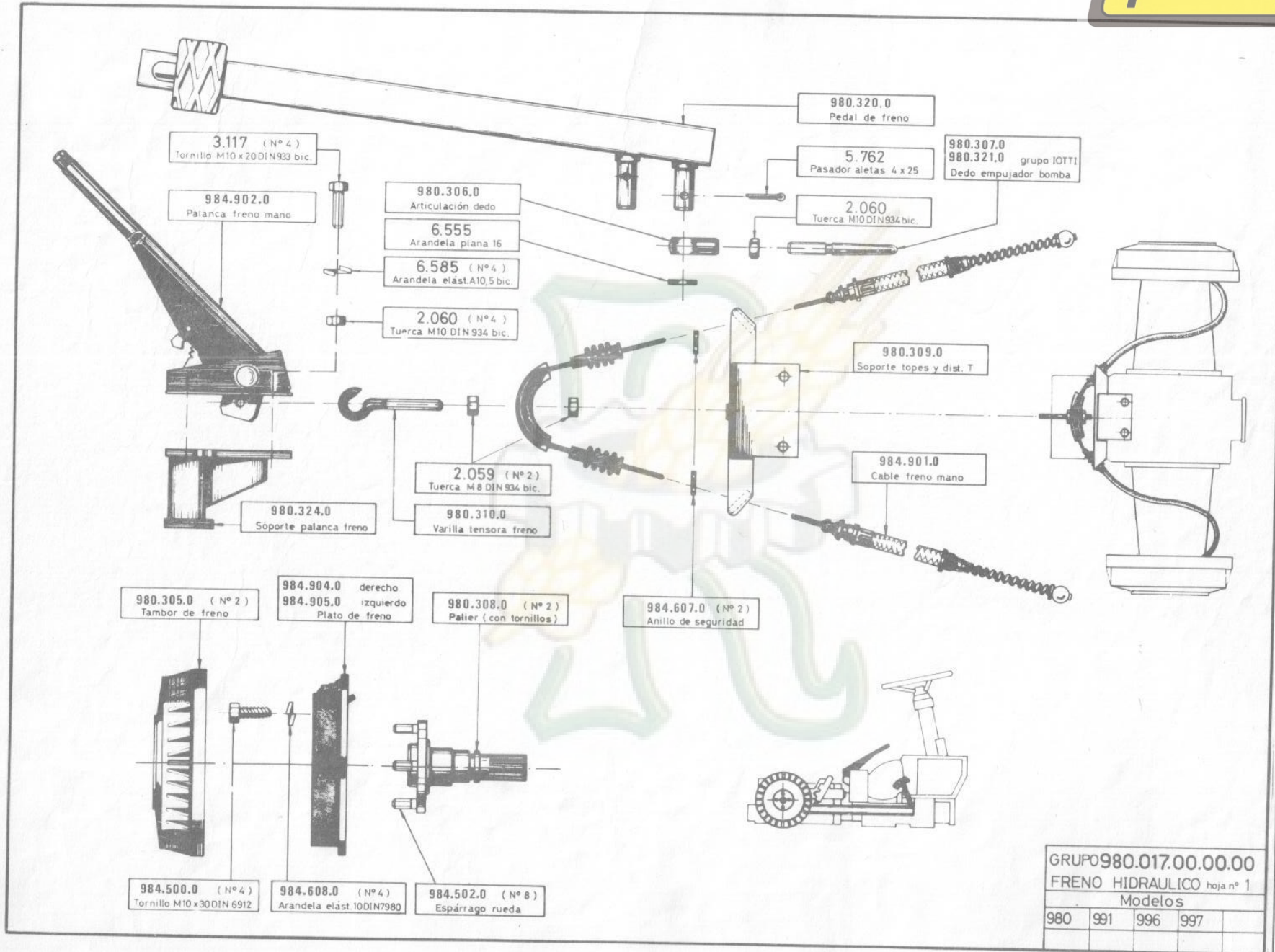

GRUPO 980.017.00.00.00
 FRENO HIDRAULICO hoja nº 1
 Modelos

980	991	996	997	
-----	-----	-----	-----	--

		EDICION
Marzo	Octubre	
83	81	

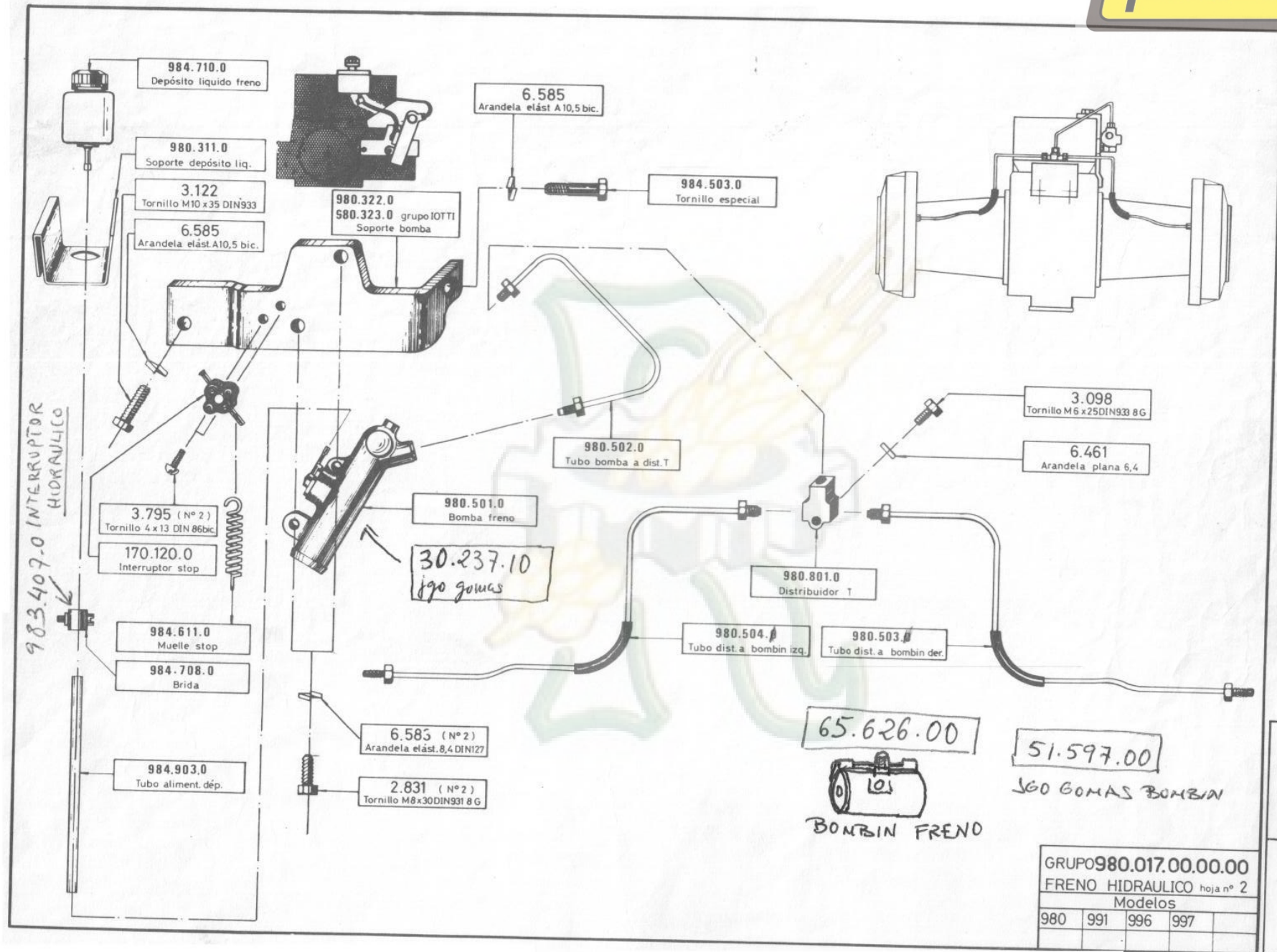

GRUPO 980.017.00.00.00
 FRENO HIDRAULICO hoja nº 2
 Modelos

980	991	996	997
-----	-----	-----	-----

EDICION
Octubre 81
Marzo 83

63.010.00 Zapata freno hidráulico Superior Derecha
 63.011.00 Zapata " " Superior Izquierda
 63.012.00 Zapata " " Superior e Inferior

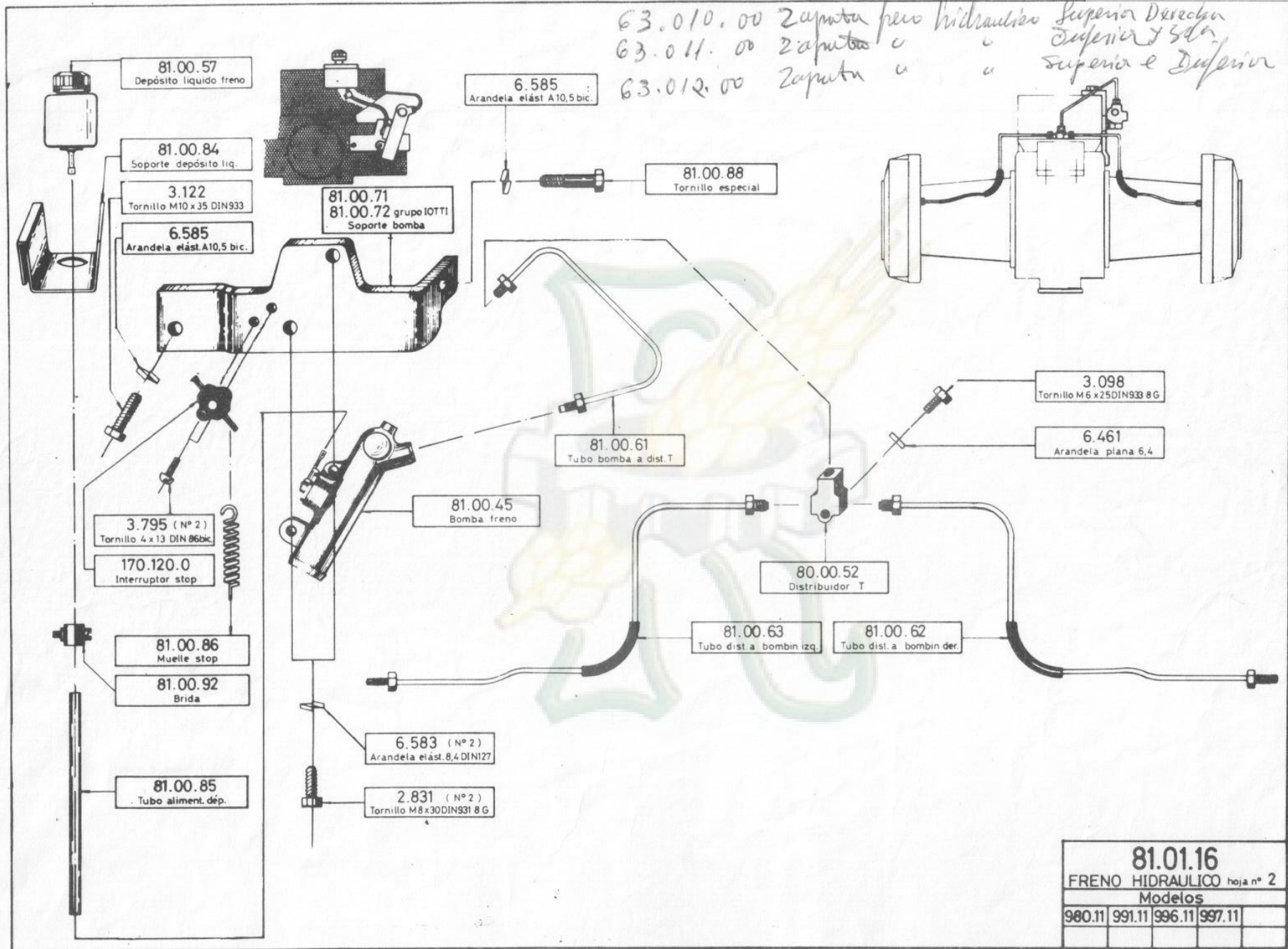

81.01.16			
FRENO HIDRAULICO hoja nº 2			
Modelos			
980.11	991.11	996.11	997.11

Octubre 81	EDICION
------------	---------