

TRACTOR TIPO 935



Design N 5
Dessin N

CAPOT, GUARDABARROS Y SOPORTES DTROS. FRONT SUPPORTS, MUDGUARD AND HOOD CAPOT, GARDE-BOUE ET SUPPORT DEVANT MOD 935

Pag.
21

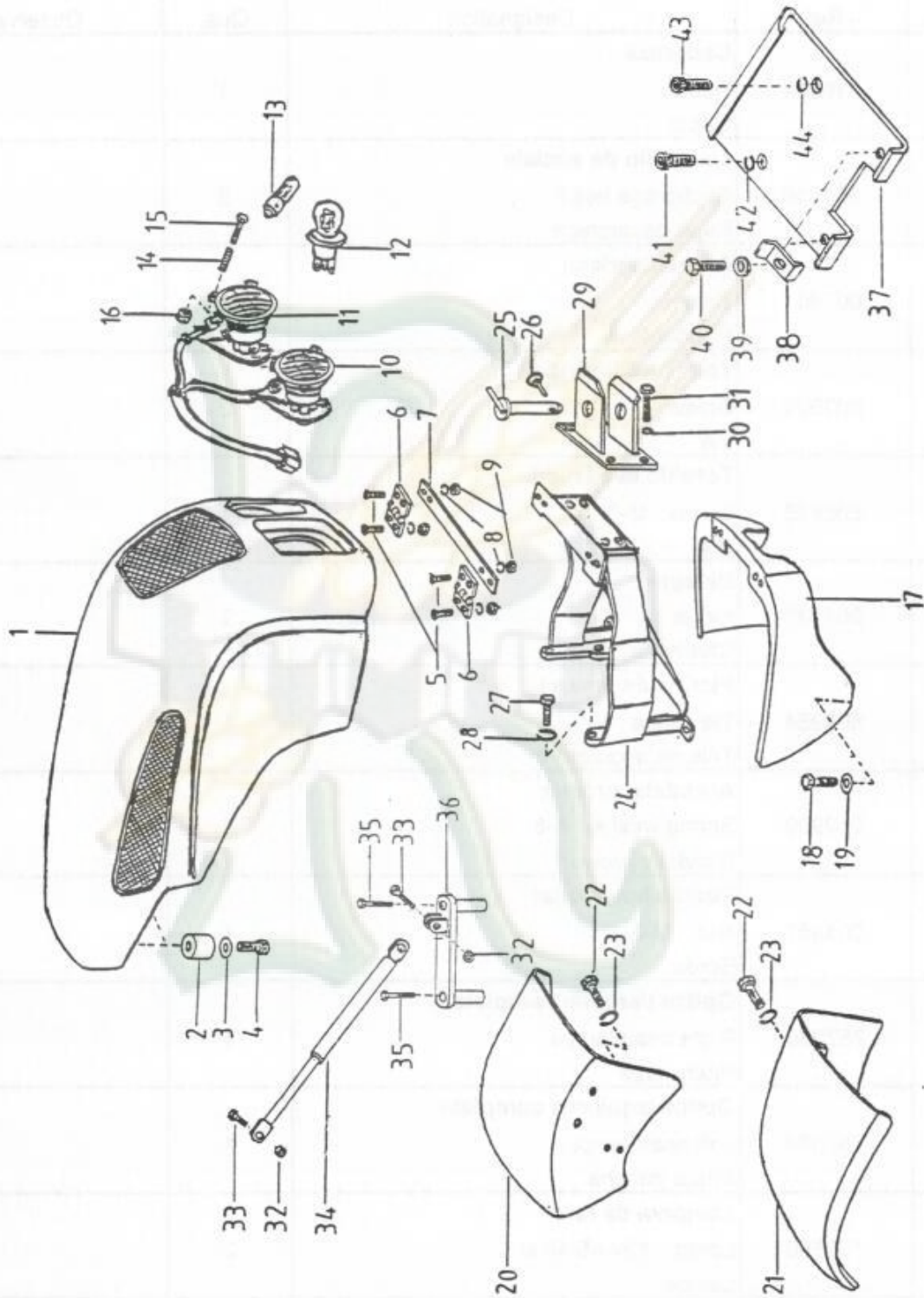

TRACTOR TIPO 935



CAPOT, GUARDABARROS Y SOPORTES DTROS.
FRONT SUPPORTS, MUDGUARD AND HOOD
CAPOT, GARDE-BOUE ET SUPPORT DEVANT
MOD 935

Pag.
22

Design N
Dessin N

Pos. Pos. Pos.	Ref. Ref. Ref.	Denominación Description Designation	Can. Qua. Qua.	Observaciones Remarks Observations
1	810654	Caperuza Hood Capot	1	
2	561910	Casquillo de anclaje Anchorage bush Bague de ancrage	2	
3	007801	Arandela plana Washer Rondelle	2	
4	002500	Tornillo cilindrico Screw Vis	2	
5	808820	Tornillo avellanado Screw M-8 Vis	4	
6	064536	Bisagra Hinge Charnière	2	
7	808954	Pletina de amarre Tie flange Tôle de ancrage	1	
8	012960	Arandela grower Spring washer A-8 Rondelle grower	4	
9	005951	Tuerca hexagonal Nut M-8 Ecrou	4	
10	757060	Optica derecha completa Right head lamps Phere droit	1	
11	757070	Optica izquierda completa Left head lamps Phare gauche	1	
12	756650	Lámpara de faro Lamp 12v-45/40 w Lampe	2	
13	769300	Lámpara Lamp 12v - 4w Lampe	2	

TRACTOR TIPO 935



Design N
Dessin N

CAPOT, GUARDABARROS Y SOPORTES DTROS.
FRONT SUPPORTS, MUDGUARD AND HOOD
CAPOT, GARDE-BOUE ET SUPPORT DEVANT
MOD 935

Pag.
23

Pos. Pos. Pos.	Ref. Ref. Ref.	Denominación Description Designation	Can. Qua. Qua.	Observaciones Remarks Observations
14	747950	Muelle de faros Spring Ressort	6	
15	002910	Tornillo cilindrico Screw M-5 x 30 Vis	6	
16	005920	Tuerca hexagonal Nut M-5 Ecrou	6	
17	811285	Frontal inferior Lower front Frontal inferieur	1	
18	001100	Tornillo hexagonal Screw M-8 x 25 Vis	2	
19	007820	Arandela plana Washer 8'40 Rondelle	2	
20	810461	Guardabarros delantero izdo. Front mudguard left Garde-boue devant gauche	1	
21	810460	Guardabarros delantero derecho Front mudguard right Garde-boue devant droite	1	
22	000550	Tornillo hexagonal Screw M-10 x 55 Vis	6	
23	012970	Arandela grower Spring washer Rondelle grower	6	
24	811301	Defensa de motor Engine protection Protection de moteur	1	
25	274446	Bulón de enganche Locking plug Cheville de blocage	1	
26	809239	Pasador con cerrojo Pin Goupille	1	

TRACTOR TIPO 935



**CAPOT, GUARDABARROS Y SOPORTES DTROS.
FRONT SUPPORTS, MUDGUARD AND HOOD
CAPOT, GARDE-BOUE ET SUPPORT DEVANT
MOD 935**

Pag.
24

Design N
Dessin N

Pos. Pos. Pos.	Ref. Ref. Ref.	Denominación Description Designation	Can. Qua. Qua.	Observaciones Remarks Observations
27	001330	Tornillo hexagonal Screw M-16 x 35 Vis	4	
28	013000	Arandela grower Spring washer Rondelle grower	4	
29	808059	Enganche delantero Front hitch Attelage avant	1	
30	012970	Arandela grower Spring washer A-10 Rondelle grower	4	
31	001160	Tornillo hexagonal Screw M-10 x 35 Vis	4	
32	006650	Tuerca autoblocante Nut M-8 Ecrou	2	
33	001100	Tornillo hexagonal Screw M-8 x 25 Vis	2	
34	808495	Amortiguador Absorbing Amortisseur		
35	000430	Tornillo hexagonal Screw M-6 x 70 Vis	2	
36	811578	Soporte de amortiguador Absorbing support Support de amortisseur	1	
37	810531	Soporte de batería Battery support Support de batterie	1	
38	765690	Patilla de amarre Tightening plate Plaque tensoure	2	
39	007820	Arandela plana Washer 8'4 Ø Rondelle	2	

TRACTOR TIPO 935



Design N
Dessin N

CAPOT, GUARDABARROS Y SOPORTES DTROS.
FRONT SUPPORTS, MUDGUARD AND HOOD
CAPOT, GARDE-BOUE ET SUPPORT DEVANT
MOD 935

Pag.
25

Pos. Pos. Pos.	Ref. Ref. Ref.	Denominación Description Designation	Can. Qua. Qua.	Observaciones Remarks Observations
40	001100	Tornillo hexagonal Screw M-16 x 25 Vis	2	
41	002180	Tornillo cilíndrico Screw M-8 x 30 Vis	1	
42	012810	Arandela grower Spring washer A-8 Rondelle grower	1	
43	002270	Tornillo cilíndrico Screw M-12 x 40 Vis	1	
44	012830	Arandela grower Spring washer A-12 Rondelle grower	1	

TRACTOR TIPO 935



Design N 11
Dessin N

MOTOR Y PROTECCIONES PROTECTIONS AND ENGINE MOTEUR ET PROTÉCTEURS MOD 935

Pag.
42

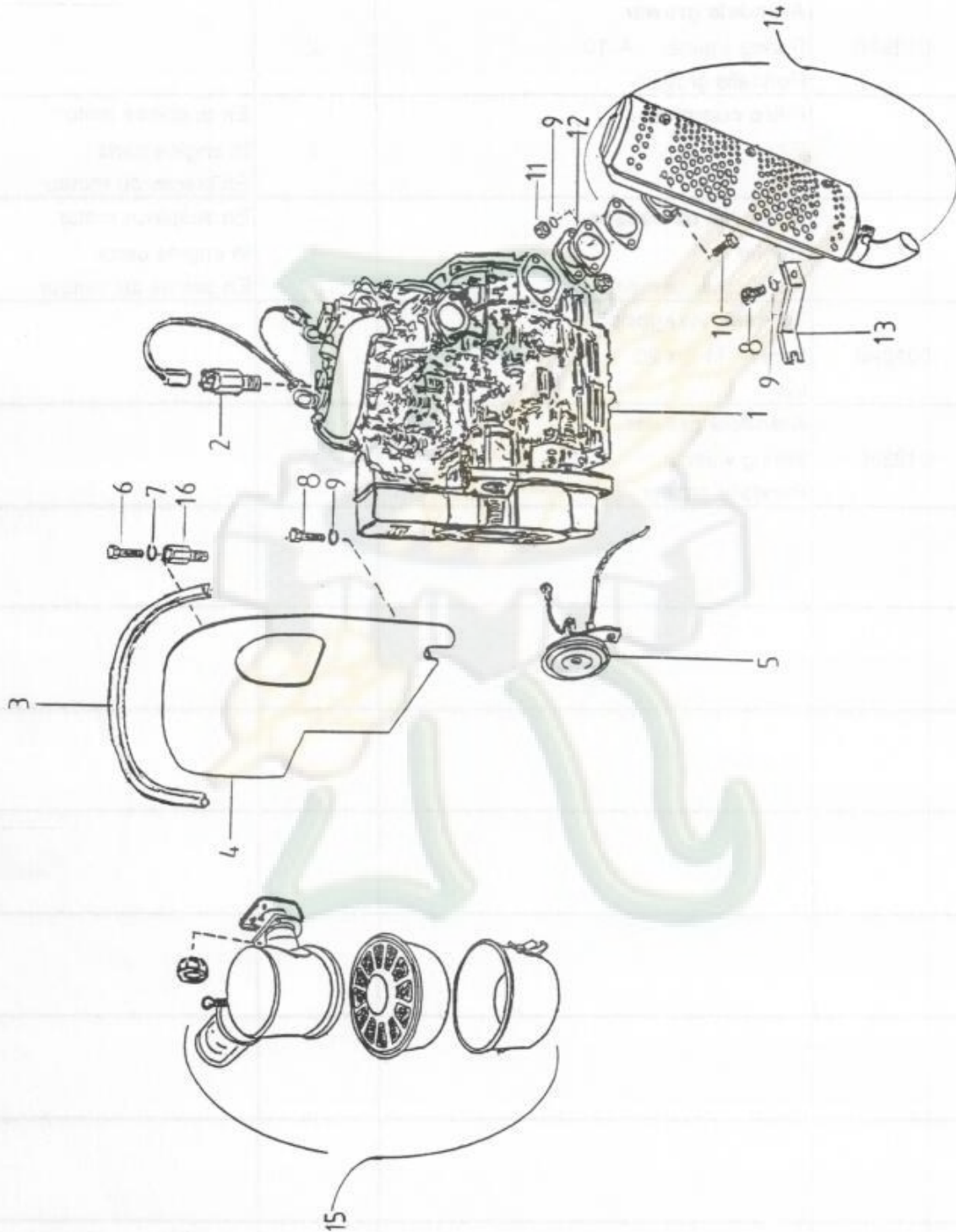

TRACTOR TIPO 935



Design N
Dessin N

MOTOR Y PROTECCIONES
PROTECTIONS AND ENGINE
MOTEUR ET PROTÉCTEURS
MOD 935

Pag.
43

Pos. Pos. Pos.	Ref. Ref. Ref.	Denominación Description Designation	Can. Qua. Qua.	Observaciones Remarks Observations
1	810998	Motor Engine 9LD626-2NR Moteur	1	
2	810809	Termorresistencia Thermoregulator Thermorégulateur	1	
3	809607	Goma de apoyo Rubber Caoutchout	1	
4	810893	Chapa de separación Separator plate Plaque trieuse	1	
5	029600	Claxon Horn buttom Avertisseur	1	
6	001130	Tornillo hexagonal Screw M-10 x 20 Vis	1	
7	012970	Arandela grower Spring washer A-10 Rondelle grower	1	
8	001090	Tornillo hexagonal Screw M-8 x 20 Vis	2	
9	012960	Arandela grower Spring ring A-8 Rondelle grower	4	
10	001100	Tornillo hexagonal Screw M-8 x 25 Vis	2	
11	005951	Tuerca hexagonal Nut M-8 Ecrou	2	
12	810895	Separador de escape Spacer of muffler Entretoise de pot d'echappement	1	
13	810903	Pletina amarre escape Fastening plate Plaque de ancrage	1	

TRACTOR TIPO 935



Design N 17
Dessin N

SISTEMA DE EMBRAGUE CLUTCH SYSTEM SYSTÈME D'EMBRAYAGE MOD 935

Pag.
70

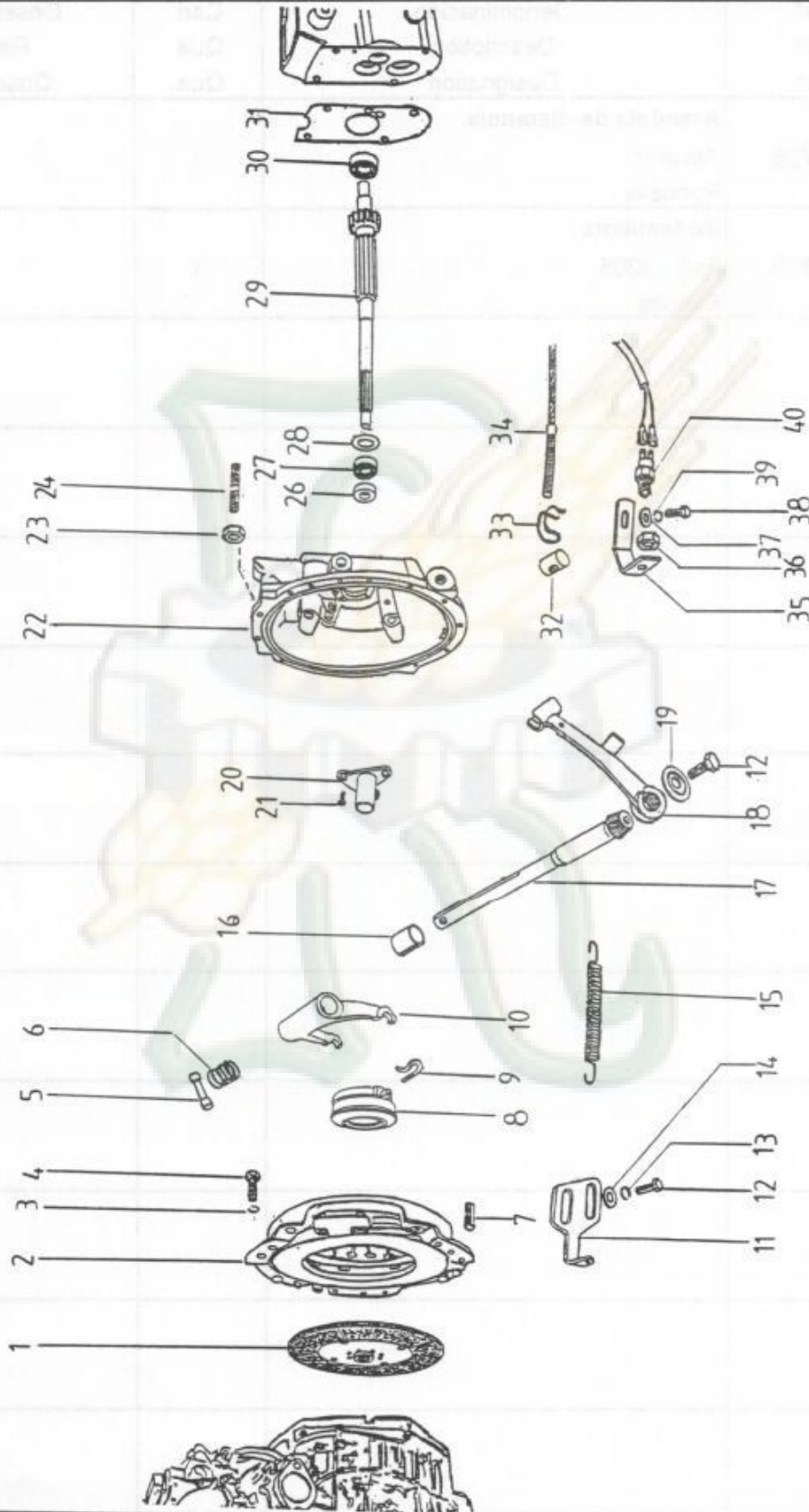

TRACTOR TIPO 935



Design N
Dessin N

17

SISTEMA DE EMBRAGUE
CLUTCH SYSTEM
SYSTÈME D'EMBRAYAGE
MOD 935

Pag.

71

Pos. Pos. Pos.	Ref. Ref. Ref.	Denominación Description Designation	Can. Qua. Qua.	Observaciones Remarks Observations
1	255683	Disco de embrague Clutch plate Disque d'embrayage	1	
2	763030	Maza de embrague Pressure plate Plateau d'embrayage	1	
3	012950	Arandela grower Spring washer Rondelle grower	6	
4	001120	Tornillo hexagonal Screw M-6 x 15 Vis	6	
5	257081	Pasador Pin Goupille	1	
6	782970	Resorte Spring Ressort	1	
7		Pasador elástico Split pin Ø 6 x 15 Goupille	3	
8	742490	Cojinete de empuje Clutch release Butée d'embrayage	1	
9	256961	Alambre de fijación Holding spring Ressort	2	
10	257421	Horquilla de embrague Clutchin fork Fourchette d'embrayage	1	
11	788521	Soporte de muelle Spring support Suppor de ressort	1	
12	001090	Tornillo hexagonal Screw M-8 x 20 Vis	3	
13	012960	Arandela grower Spring washer Rondelle grower	2	

TRACTOR TIPO 935



Design N
Dessin N

17

SISTEMA DE EMBRAGUE CLUTCH SYSTEM SYSTÈME D'EMBRAYAGE MOD 935

Pag.
72

Pos. Pos. Pos.	Ref. Ref. Ref.	Denominación Description Designation	Can. Qua. Qua.	Observaciones Remarks Observations
14	007820	Arandela plana Washer Rondelle	1	
15	791800	Muelle palanca embrague Spring Ressort	1	
16	803614	Casquillo GLY Bush Bague	1	
17	257030	Eje de embrague Clutch shaft Arbre d'embrayage	1	
18	811239	Palanca de embrague Coupling lever Doigt d'embrayage	1	
19	257131	Arandela de seguridad Safety washer Rondelle d' securite	1	
20	804873	Guía de empujador Bearing sleeve Guide	1	
21	804976	Tornillo avellanado Screw 8 x 15 Vis	3	
22	804875	Carcasa de embrague Clutch housing Carter d'embrayage	1	
23	800630	Carter d'embrayage Nut M-10 Ecrou	10	
24	798980	Espárrago Stud M-10 x 5 Goujon	10	
25				
26	019790	Retén Seal 25 x 47 x 7 Bague	1	

TRACTOR TIPO 935



Design N
Dessin N

SISTEMA DE EMBRAGUE
CLUTCH SYSTEM
SYSTÈME D'EMBRAYAGE
MOD 935

Pag.
73

Pos. Pos. Pos.	Ref. Ref. Ref.	Denominación Description Designation	Can. Qua. Qua.	Observaciones Remarks Observations
27	801680	Rodamiento Bearing 305 NUP Roulement	1	
28	801728	Arandela de distancia Washer Rondelle	1	
29	756930	Eje primario Main shaft gear Engranage arbre princip	1	
30	025820	Rodamiento Bearing 6305 Roulement	1	
31	041461	Junta carcasa de embrague Gasket Joint	1	
32	126540	Bulón de reglaje Power setting bolt Boulon de reglage	1	
33	126760	Muelle de fijación Locking spring Ressort de blocage	1	
34	808447	Cable de embrague Clutch cable Câble d'embrayage	1	
35	810475	Chapa soporte Support Support	1	
36	006380	Tuerca hexagonal Nut M-14 x 1'5 Erou	1	
37	007840	Arandela plana Washer Rondelle	1	
38	001030	Tornillo hexagonal Screw M-10 x 25 Vis	1	
39	012970	Arandela grower Spring washer A-10 Rondelle grower	1	

TRACTOR TIPO 935



Design N 20
Dessin N

CAJA DE CAMBIOS DELANTERA FRONT GEAR BOX BOITE DE VITESSES AVANT MODS 940"N" - 935

Pag.
85

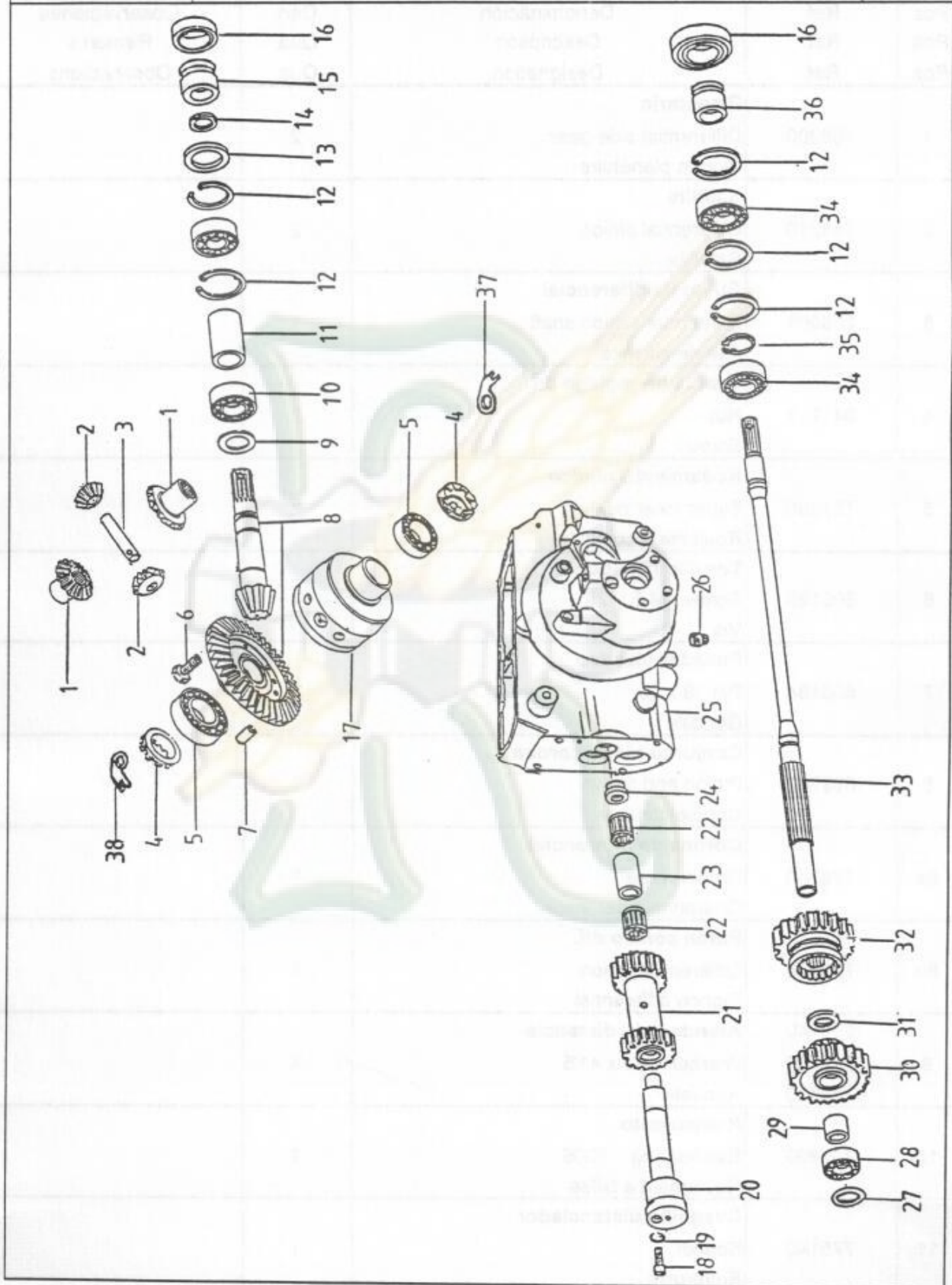

TRACTOR TIPO 935



Design N Dessin N		CAJA DE CAMBIOS DELANTERA FRONT GEAR BOX BOITE DE VITESSES AVANT MODS 940"N" - 935			Pag. 86
Pos. Pos. Pos.	Ref. Ref. Ref.	Denominación Description Designation	Can. Qua. Qua.	Observaciones Remarks Observations	
1	768200	Planetario Differential side gear Pignon planétaire	2		
2	768210	Satélite Differential pinion Satellite	2		
3	256081	Bulón de diferencial Differential pinion shaft Axe de satellite	1		
4	041711	Tuerca de reglaje dif. Nut Ecrou	2		
5	751360	Rodamiento cónico Taper roller bearing Roulement conique	2		
6	800125	Tornillo hexagonal Screw M-8 x 25 Vis	4		
7	800184	Pasador elástico Pin 9 x 20 Goupille	3		
8	803702	Conjunto piñón corona Pinion and crown Couple conique	1		
8a	775240	Corona de diferencial Crown wheel Couronne differentiel	1		
8b	775230	Piñón cónico dif. Differential pinion Pignon differentiel	1		
9	010740 010750 753630	Arandela de distancia Washer 30 x 41'5 Rondelle	X		
10	767890	Rodamiento Ball bearing 2306 Roulement á billes	1		
11	775140	Casquillo distanciador Spacer Entretoise	1		

TRACTOR TIPO 935



Design N 20
Dessin N

CAJA DE CAMBIOS DELANTERA FRONT GEAR BOX BOITE DE VITESSES AVANT MODS 940"N" - 935

Pag.
87

Pos. Pos. Pos.	Ref. Ref. Ref.	Denominación Description Designation	Can. Qua. Qua.	Observaciones Remarks Observations
12	013950	Arandela seeger Spring ring Bague	5	
13	742830	Arandela tope Washer Rondelle	1	
14	775150	Tuerca de fijación Nut Ecrou	1	
15	775250	Casquillo apoyo retén Bush Bague	1	
16	755880	Retén doble labio Seal 45 x 72 x 10 Bague	2	
17	768191	Carcasa de diferencial Differential case Carter de différentiel	1	
18	002190	Tornillo cilíndrico Screw M-10 x 20 Vis	1	
19	012820	Arandela grower Spring washer Rondelle grower	1	
20	799360	Eje soporte piñón inv. Reverse idler gear shaft Arbre de marche arrière	1	
21	799370	Piñón inversor Reverse gear Engrimage de marche arrière	1	
22	787950	Corona de agujas Roller racer Couronne d'roulett	2	
23	799530	Tubo de distancia Spacer Entretoise	1	
24	041541	Casquillo tope Bush Bague	1	

TRACTOR TIPO 935



Design in
Dessin N

CAJA DE CAMBIOS DELANTERA FRONT GEAR BOX BOITE DE VITESSES AVANT MODS 940"N" - 935

Pag.

88

Pos. Pos. Pos.	Ref. Ref. Ref.	Denominación Description Designation	Can. Qua. Qua.	Observaciones Remarks Observations
25	805624	Carter delantero Front casing Carter avant	1	
26	801239	Tapón de purga Plug Bouchon	1	
27	010900	Arandela de distancia Washer Rondelle	1	
28	751350	Rodamiento Bearing 306 NUP Roulement	1	
29	743320	Casquillo de bronce Bush Bague	1	
30	799110	Rueda loca Idier pinion Pignon	1	
31	165990	Arandela de distancia Washer Rondelle	1	
32	743330	Piñón desplazable Sliding gear Pignon baladeur	1	
33	743300	Eje principal Mains shaft Arbre principal	1	
34	025840	Rodamiento Bearing 6306 Roulement	2	
35	253080	Arandela seeger Spring ring 30a x 2 Bague	1	
36	741400	Casquillo apoyo retén Bush Bague	1	
37	041781	Chapa de seguridad izda. Left safety plate Plaque de securite gauche	1	

TRACTOR TIPO 935



CUERPO DE ARTICULACIÓN DELANTERO FRONT YOKE BODY CORPS D'ARTICULATION AVANT MOD 940"N" - 935

Pag.

92

Design N 22
Dessin N

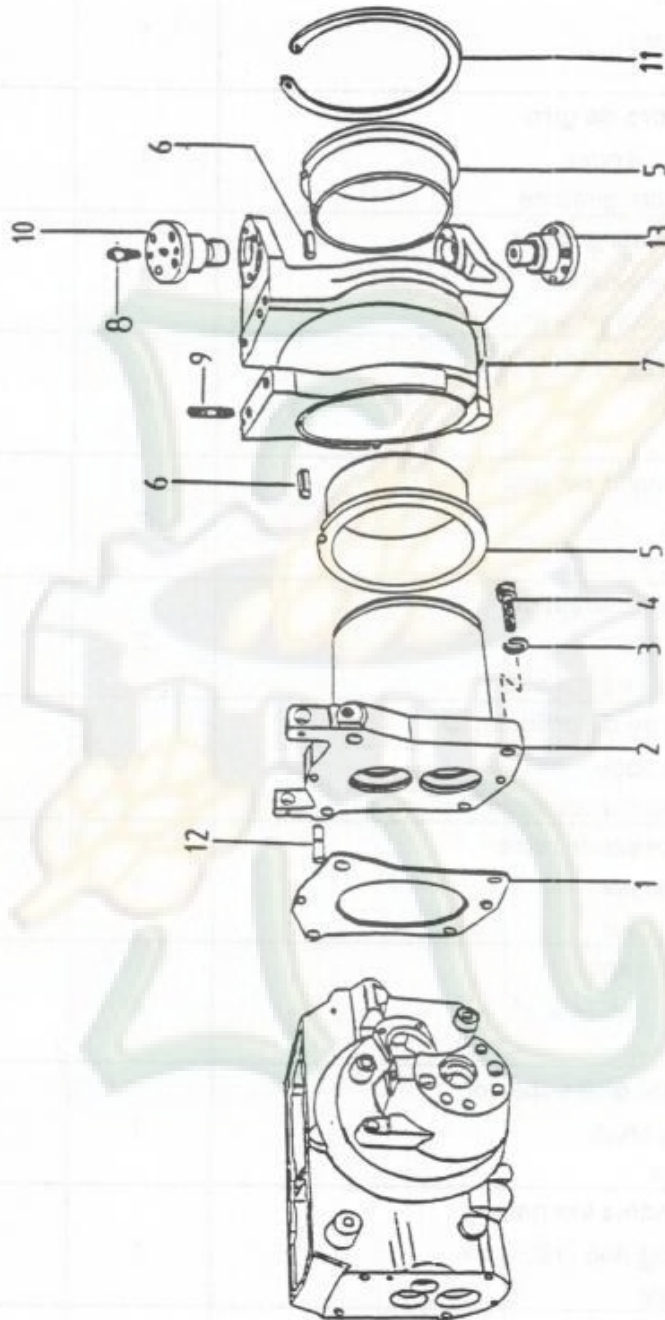

TRACTOR TIPO 935



Design N 22
Dessin N

CUERPO DE ARTICULACIÓN DELANTERO
FRONT YOKE BODY
CORPS D'ARTICULATION AVANT
MOD 940"N" - 935

Pag.
93

Pos. Pos. Pos.	Ref. Ref. Ref.	Denominación Description Designation	Can. Qua. Qua.	Observaciones Remarks Observations
1	792900	Junta Gasket Joint	1	
2	775220	Cilindro de giro Turn cylinder Cylindre giratoire	1	
3	012850	Arandela grower Spring washer Rondelle grower	4	
4	797380	Tornillo cilíndrico Screw Vis	4	
5	795300	Casquillo de giro Bush Bague	2	
6	016180	Pasador elástico Split pin Goupille élastique	2	
7	790430	Cuerpo de articulación Joint body Corps d'articulation	1	
8	784920	Engrasador recto Lubricator Graisseur	1	
9	763860	Espárrago Stud M-14 x 50 Goujon	4	
10	804546	Eje de giro superior Main shaft Arbre	1	
11	791630	Arandela seeger Spring ring 180 a x 4 Bague	1	
12	016311	Pitón guía Centering pin Goujon centrage	2	
13	790500	Eje de giro inferior Main shaft Arbre	1	

TRACTOR TIPO 935



CUERPO DE ARTICULACIÓN TRASERO BACKWARD YOKE BODY CORPS D'ARTICULATION ARRIÈRE MODS 940"N" - 935

Pag.
100

Design N 24
Dessin N

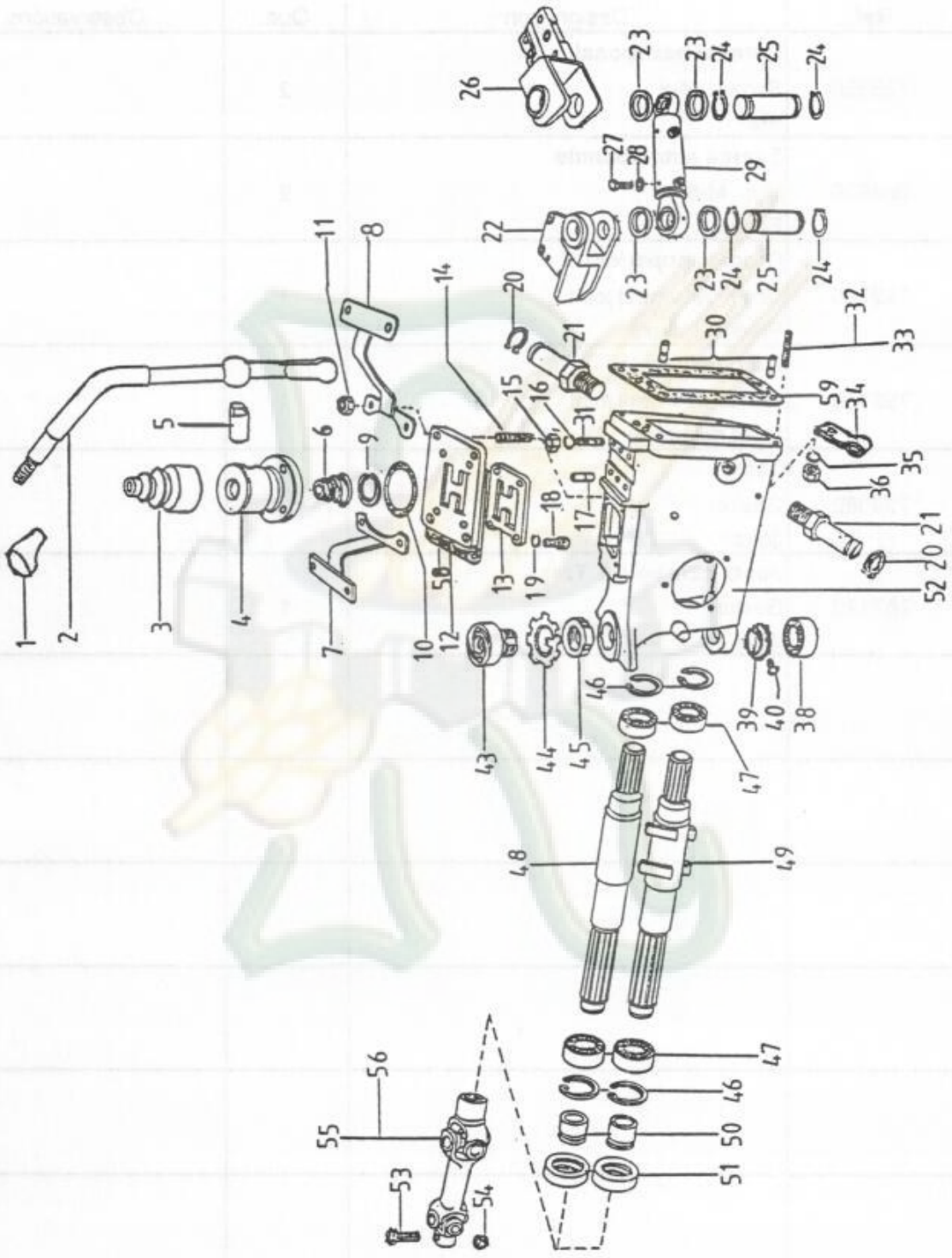

TRACTOR TIPO 935



Design N 24
Dessin N

CUERPO DE ARTICULACIÓN TRASERO
BACKWARD YOKE BODY
CORPS D'ARTICULATION ARRIÈRE
MODS 940"N" - 935

Pag.
101

Pos. Pos. Pos.	Ref. Ref. Ref.	Denominación Description Designation	Can. Qua. Qua.	Observaciones Remarks Observations
1	801079	Pomo Knob Poignée	1	
2	759110	Palanca de cambio Gearshift lever Levier de changement	1	
3	804180	Fuelle de palanca Rubber boot Socque caoutchouc	1	
4	759100	Cojinete esférico Shifter ball cupola Bague	1	
5	049931	Chaveta de cambio Gearshift lever pin Clavette	1	
6	042311	Muelle de palanca Spring Ressort	1	
7	804107	Soporte delantero Front support Support avant	1	
8	804108	Soporte trasero Rear support Support arrière	1	
9	013800	Arandela seeger Spring ring 42i x 1'75 Bague	1	
10	759090	Junta de cojinete Gasket Joint	1	
11	006660	Tuerca autoblocante Nut M-10 Ecrou	4	
12	759070	Placa H de velocidades Gearshift plate Plaquette de changement	1	
13	802357	Suplemento chapa H Gearshift plate supplement Supplement plaquette H	1	

TRACTOR TIPO 935



Design N Dessin N		CUERPO DE ARTICULACIÓN TRASERO BACKWARD YOKE BODY CORPS D'ARTICULATION ARRIÈRE MODS 940"N" - 935			Pag. 102
Pos. Pos. Pos.	Ref. Ref. Ref.	Denominación Description Designation	Can. Qua. Qua.	Observaciones Remarks Observations	
14	004560	Espárrago Stud M-10 x 20 Goujon	4		
15	006300	Tuerca hexagonal Nut M-12 Erou	4		
16	012980	Arandela grower Spring washer Rondelle grower	4		
17	004560	Pitón guía Centering pin Goujon de centrage	2		
18	002170	Tornillo cilíndrico Screw M-8 x 20 Vis	4		
19	012810	Arandela grower Spring washer A-8 Rondelle grower	4		
20	013300	Arandela seeger Spring ring 25 X 1'5 Bague	2		
21	810877	Eje soporte giro pedal Swivel screw Vis á tourner	2		
22	767840	Soporte delantero Front support Support avant	1		
23	767880	Arandela de separación Spacer Entretoise	4		
24	013380	Arandela seeger Spring ring Bague	4		
25	767870	Bulón cilíndrico Pin Pivot	2		
26	802313	Soporte trasero Rear support Support arriere	1		

TRACTOR TIPO 935



Design N 24
Dessin N

CUERPO DE ARTICULACIÓN TRASERO
BACKWARD YOKE BODY
CORPS D'ARTICULATION ARRIÈRE
MODS 940"N" - 935

Pag.
103

Pos. Pos. Pos.	Ref. Ref. Ref.	Denominación Description Designation	Can. Qua. Qua.	Observaciones Remarks Observations
27	803072	Tornillo hexagonal Screw M-6 x 5 Vis	2	
28	008610	Arandela junta Washer Rondelle	2	
29	805911	Cilindro de dirección Steering cylinder Cylindre de commande	1	
30	016311	Pitón guía Centering pin Goujon centrage	2	
31	753380	Espárrago Stud M-12 x 35 Goujon	4	
32	753370	Espárrago Stud M-14 x 40 Goujon	3	
33	763860	Espárrago Stud M-14 x 50 Goujon	1	
34	741700	Abrazadera Clamp Bride	1	
35	012990	Arandela grower Spring washer Rondelle grower	4	
36	005990	Tuerca hexagonal Nut M-14 Ecrou	4	
37				
38	768750	Rodamiento Bearing 6305 Roulement	1	
39	790530	Tapa de rodamiento Cover Couvercle	1	

TRACTOR TIPO 935



CUERPO DE ARTICULACIÓN TRASERO
BACKWARD YOKE BODY
CORPS D'ARTICULATION ARRIÈRE
MODS 940"N" - 935

Pag.
104

Pos. Pos. Pos.	Ref. Ref. Ref.	Denominación Description Designation	Can. Qua. Qua.	Observaciones Remarks Observations
40	263900	Engrasador recto Lubricator Graisseur	1	
41				
42				
43	804547	Casquillo de giro Bush Bague	1	
44	803461	Arandela de seguridad Safety washer Rondelle de securite	1	
45	803460	Tuerca de fijación Nut Ecrou	1	
46	013950	Arandela seeger Spring ring Bague	4	
47	025840	Rodamiento Bearing 6306 Roulement	4	
48	802315	Eje intermedio superior Intermediate shaft upper Axe intermediaire superieur	1	
49	802316	Eje intermedio inferior Intermediate shaft inf. Axe intermediaire inf.	1	
50	741400	Casquillo apoyo retén Bush Bague	2	
51	755880	Retén doble labio Seal 45 x 72 x 10 Bague	2	
52	804385	Cuerpo de articulación Backward yoke body Corps d'articulation arriere	1	

TRACTOR TIPO 935



Design N 24
Dessin N

CUERPO DE ARTICULACIÓN TRASERO
BACKWARD YOKE BODY
CORPS D'ARTICULATION ARRIÈRE
MODS 940"N" - 935

Pag.
105

Pos. Pos. Pos.	Ref. Ref. Ref.	Denominación Description Designation	Can. Qua. Qua.	Observaciones Remarks Observations
53	135380	Tornillo hexagonal Screw M-8 Vis	2	
54	006650	Tuerca autoblocante Nut M-8 Ecrou	2	
55	792745	Cruceta superior Universal wheel joint Pivot de sûreté	1	
56	792750	Cruceta inferior Universal wheel joint Pivot de sûreté	1	
58	759080	Junta Gasket Joint	1	
59	767130	Junta cuerpo art. Tras. Gasket Joint	1	