

TRACTOR TIPO 980

pasquali

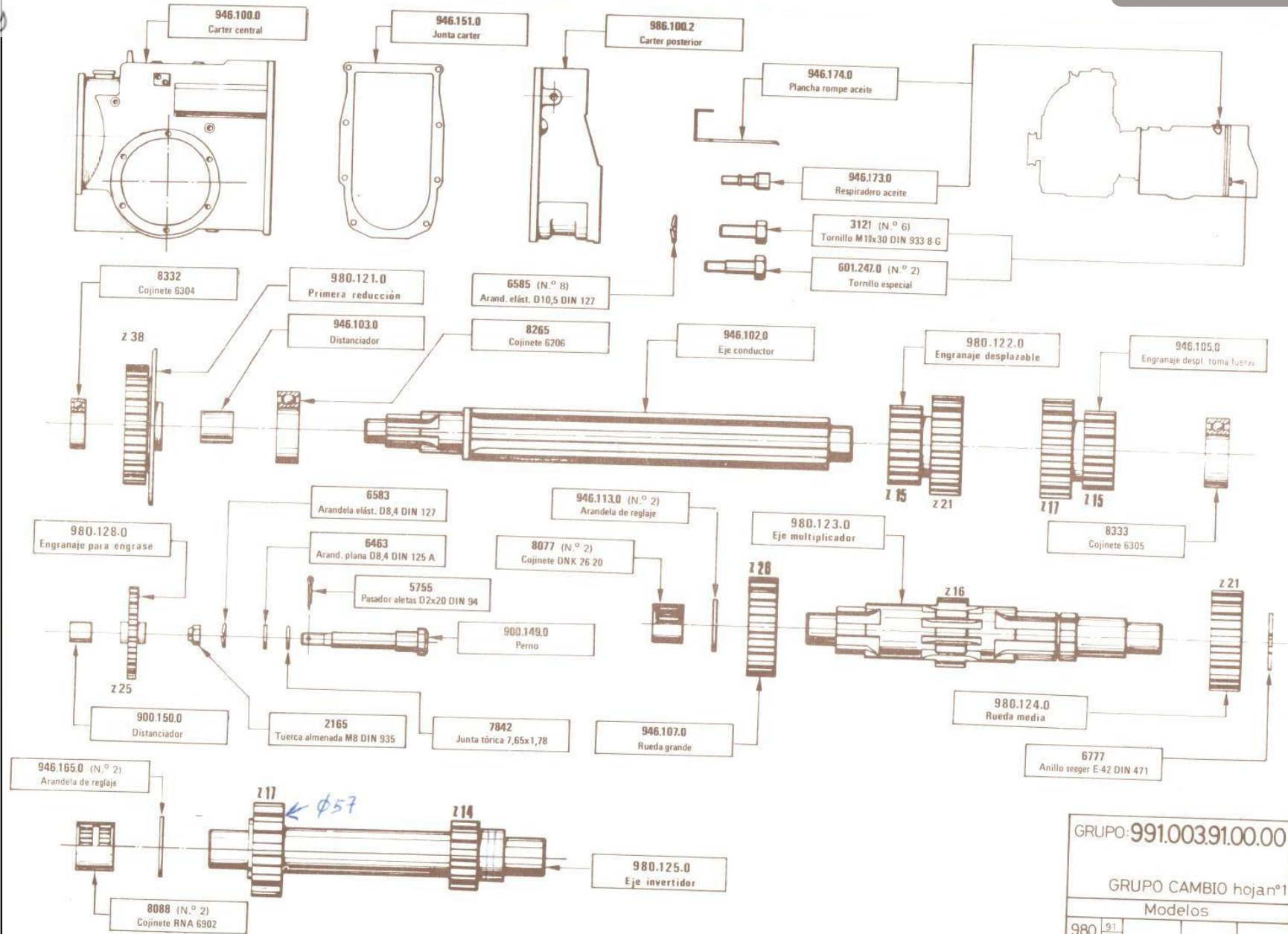

GRUPO: 991.003.91.00.00
 GRUPO CAMBIO hojanº1
 Modelos
 980 91 95

EDICION	Octubre 81
	Marzo 83

TRACTOR TIPO 980

pasquali

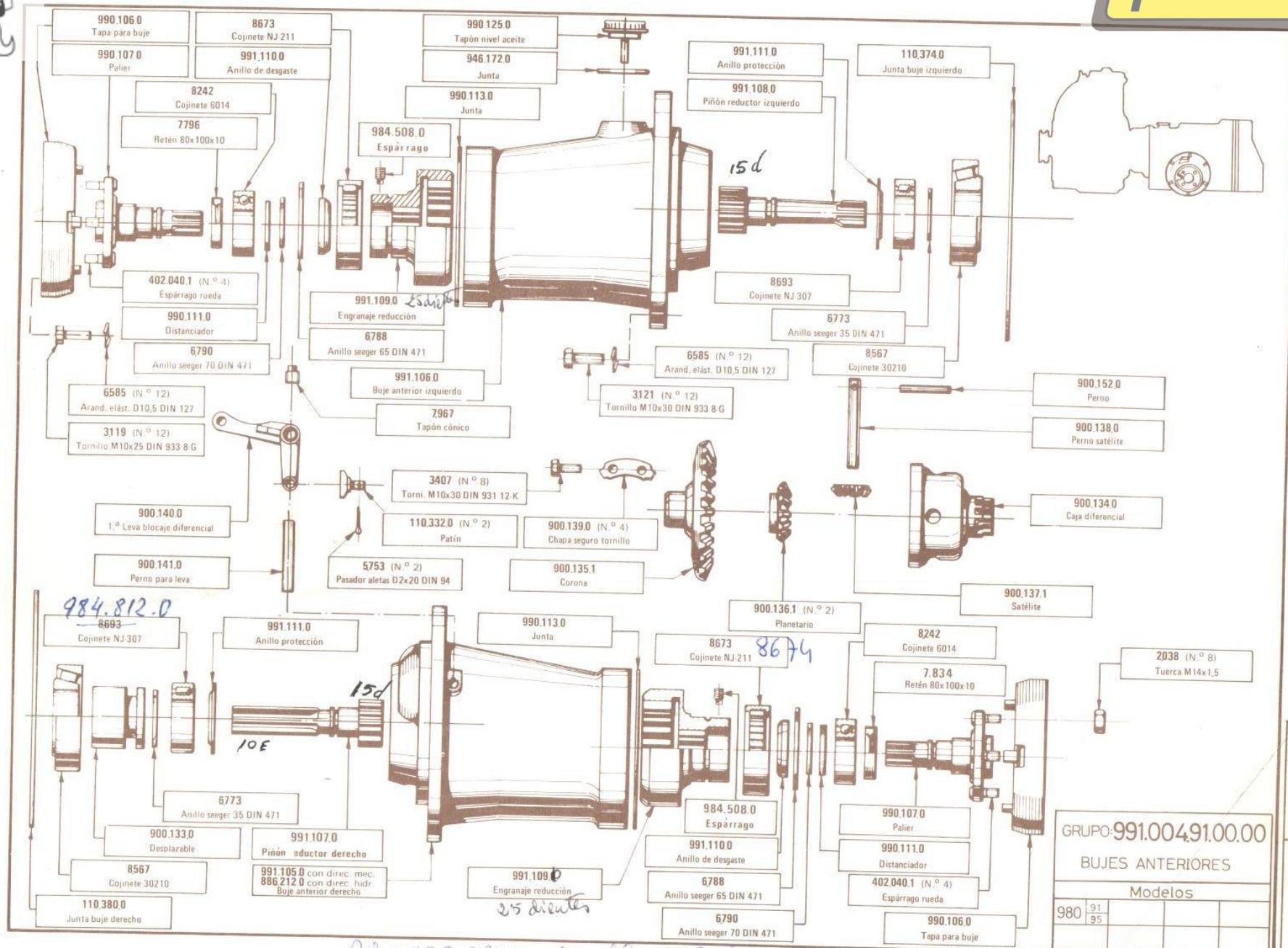

GRUPO: 991.004.91.00.00
BUJES ANTERIORES
 Modelos

980	91		
	95		

EDICION	Octubre 81
	Marzo 83

Ref. → 899.224.4 Arandelas de Refleje.

TRACTOR TIPO 980

pasquali

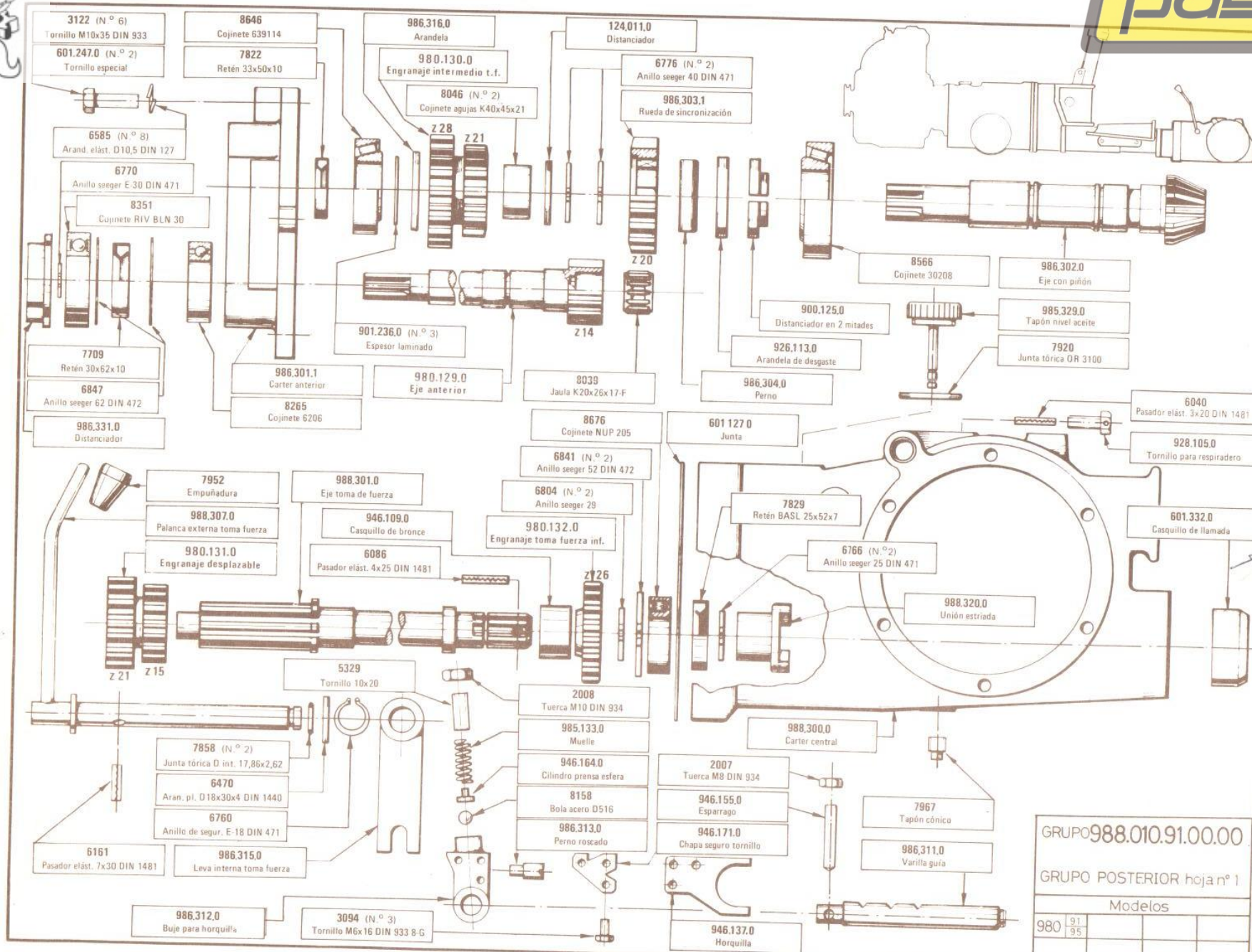

110.379.0

GRUPO 988.010.91.00.00	
GRUPO POSTERIOR hoja n.º 1	
Modelos	
980	91 95

EDICION	Octubre 81
	Marzo 83

TRACTOR TIPO 980

pasquali

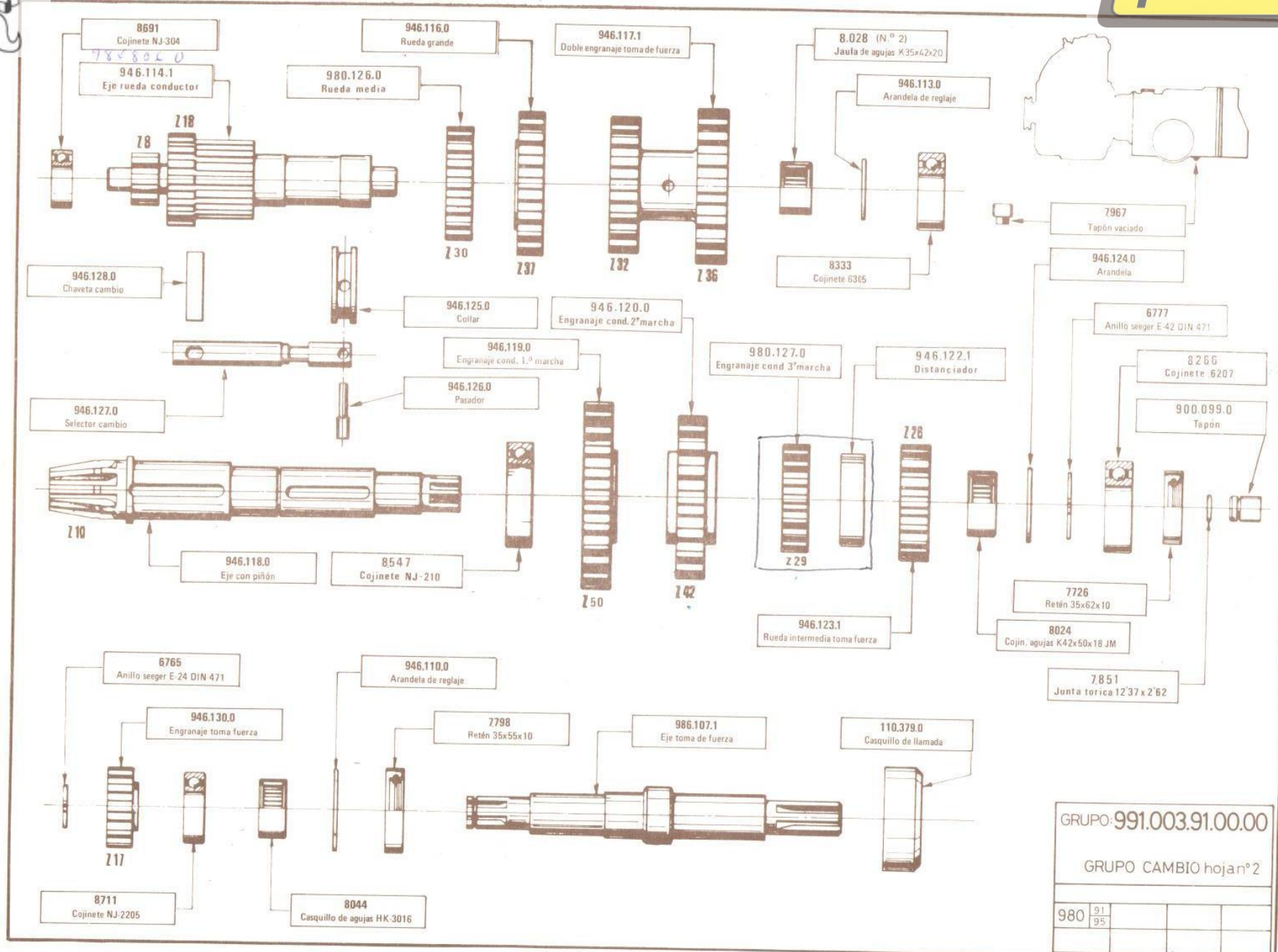

GRUPO: 991.003.91.00.00
 GRUPO CAMBIO hojan° 2
 980 91 95

			EDICION
	Octubre	81	
	Marzo	83	

TRACTOR TIPO 980

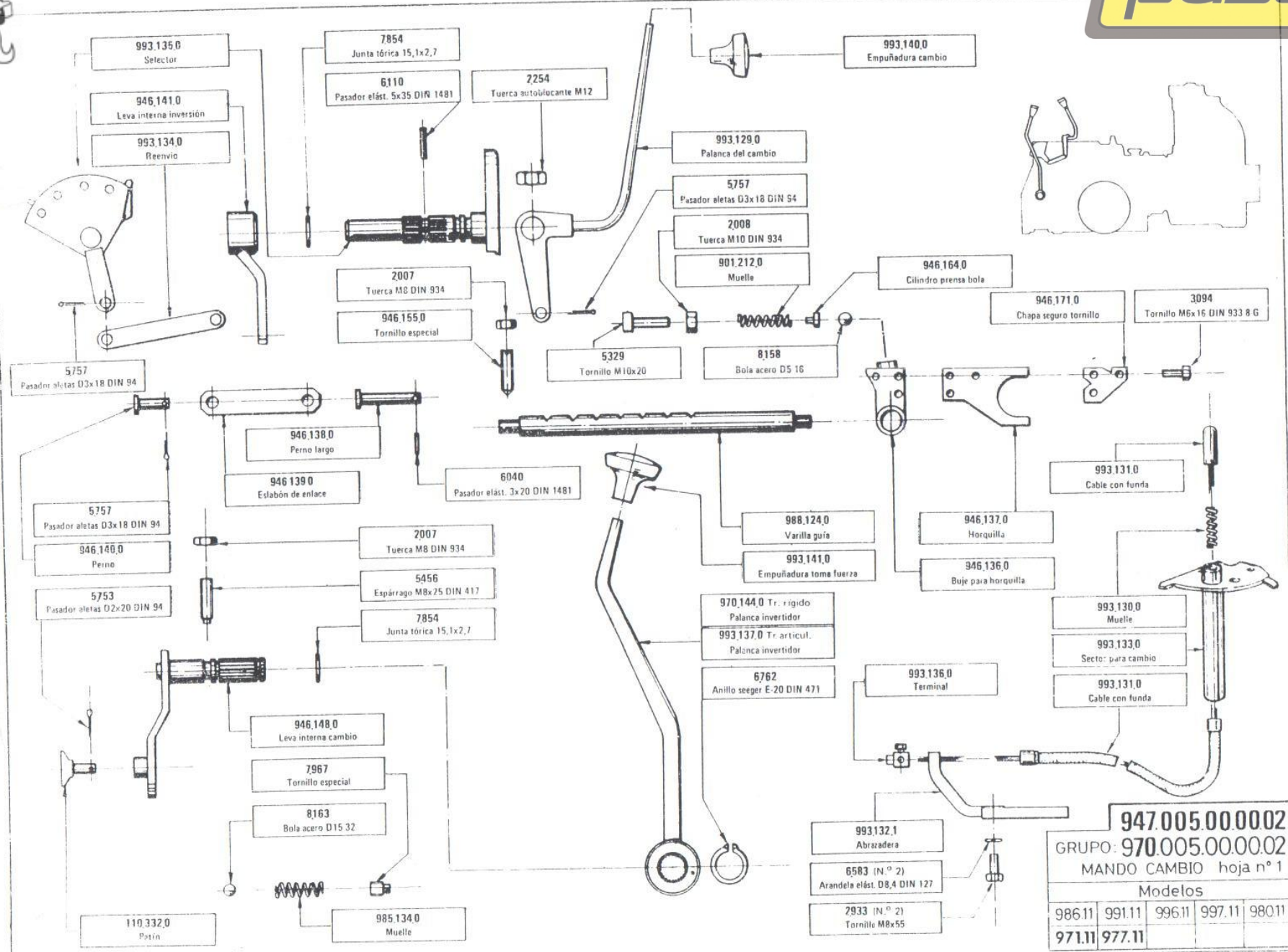

947.005.00.00.02
 GRUPO: 970.005.00.00.02
 MANDO CAMBIO hoja nº 1
 Modelos

986.11	991.11	996.11	997.11	980.11
971.11	977.11			

JUNIO 81
 EDICION

TRACTOR TIPO 980

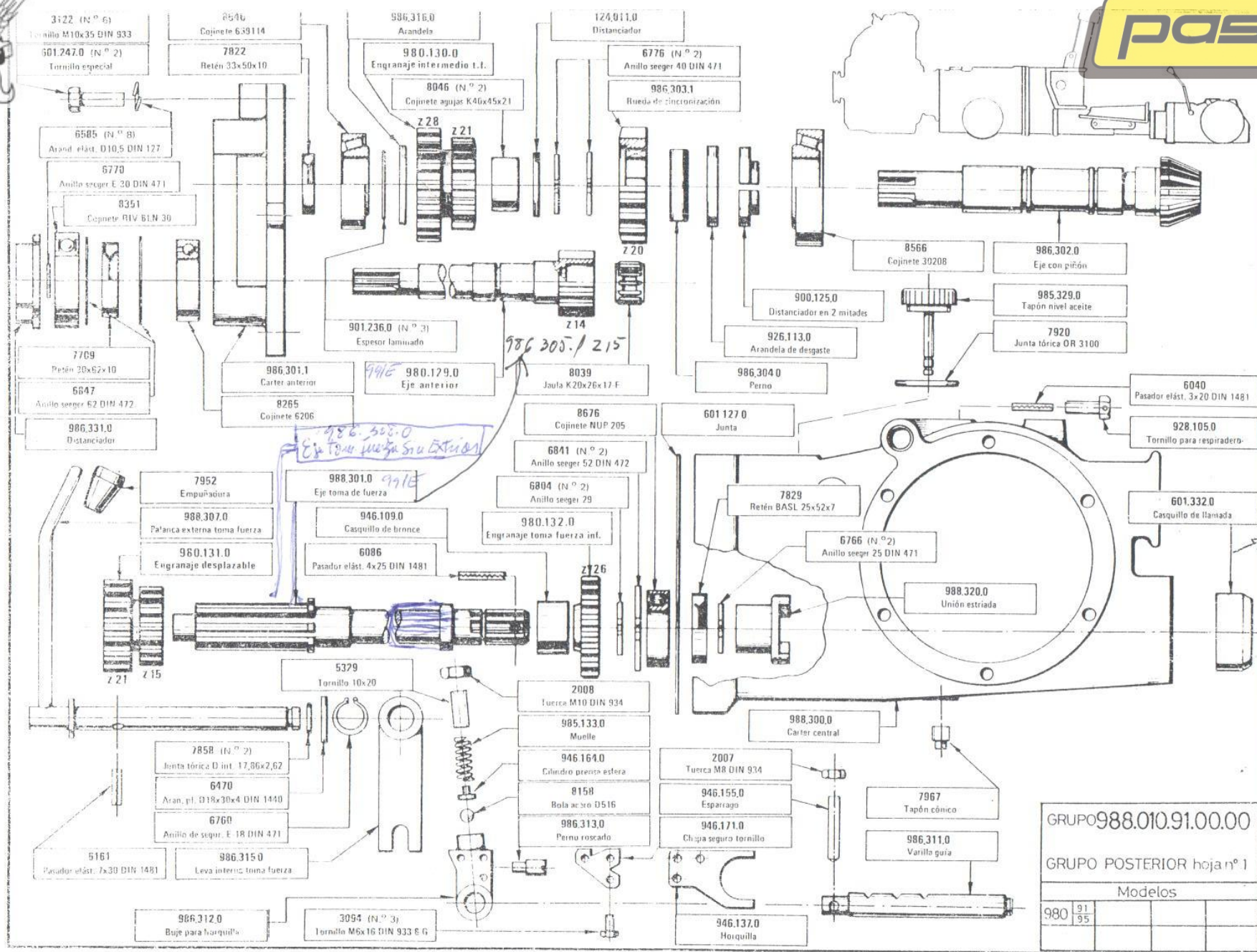

986.308.0 Eje toma fuerza sin estriada

986.305.1 / 215

110-379.0

GRUPO 988.010.91.00.00	
GRUPO POSTERIOR hoja nº 1	
Modelos	
980	91 95

EDICION
Octubre 81
Marzo 83



TRACTOR TIPO 980

pasquali

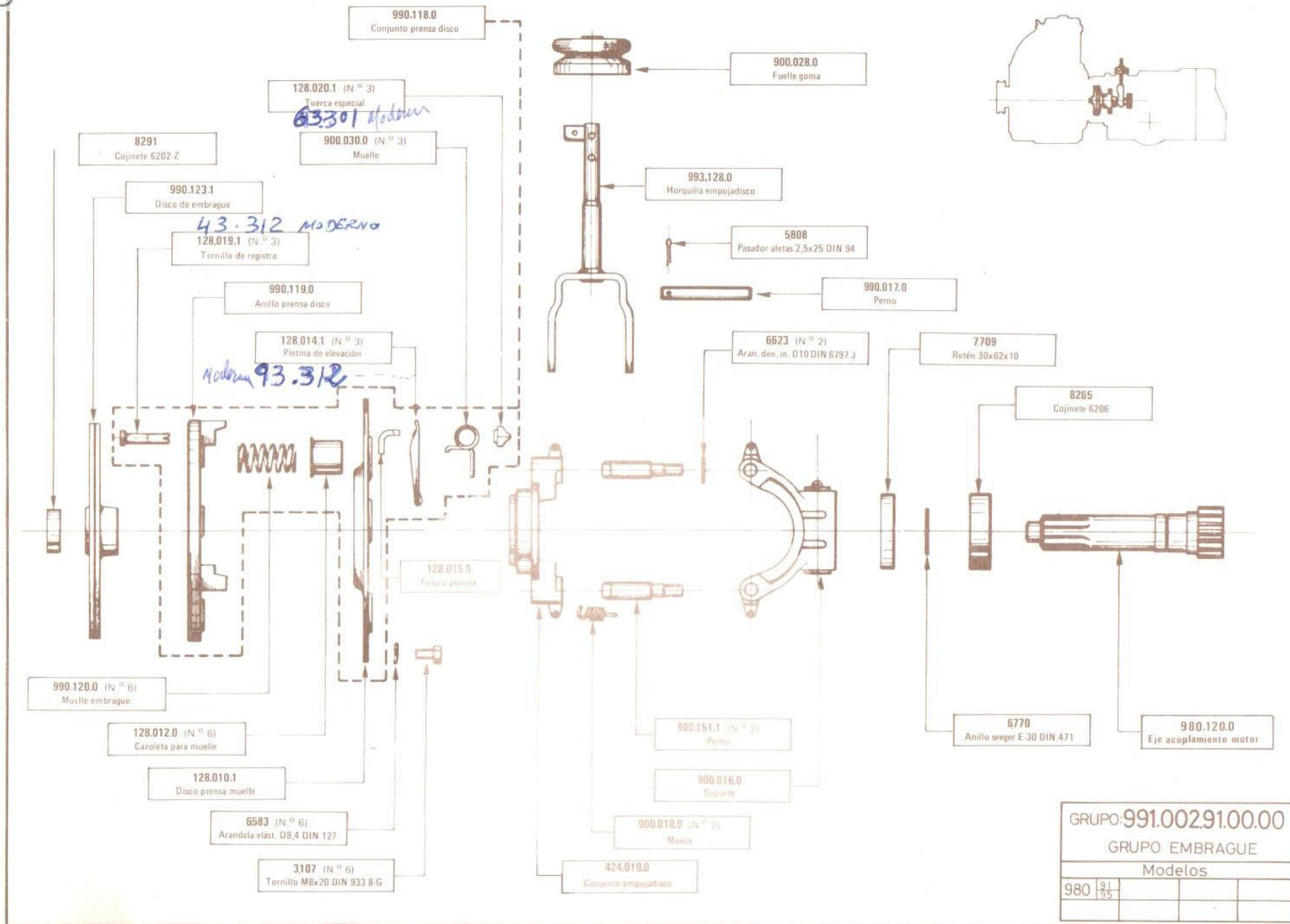

GRUPO: 991.002.91.00.00	
GRUPO EMBRAGUE	
Modelos	
980	91/95

EDICION
Octubre 81
Marzo 83

TRACTOR TIPO 980

pasquali

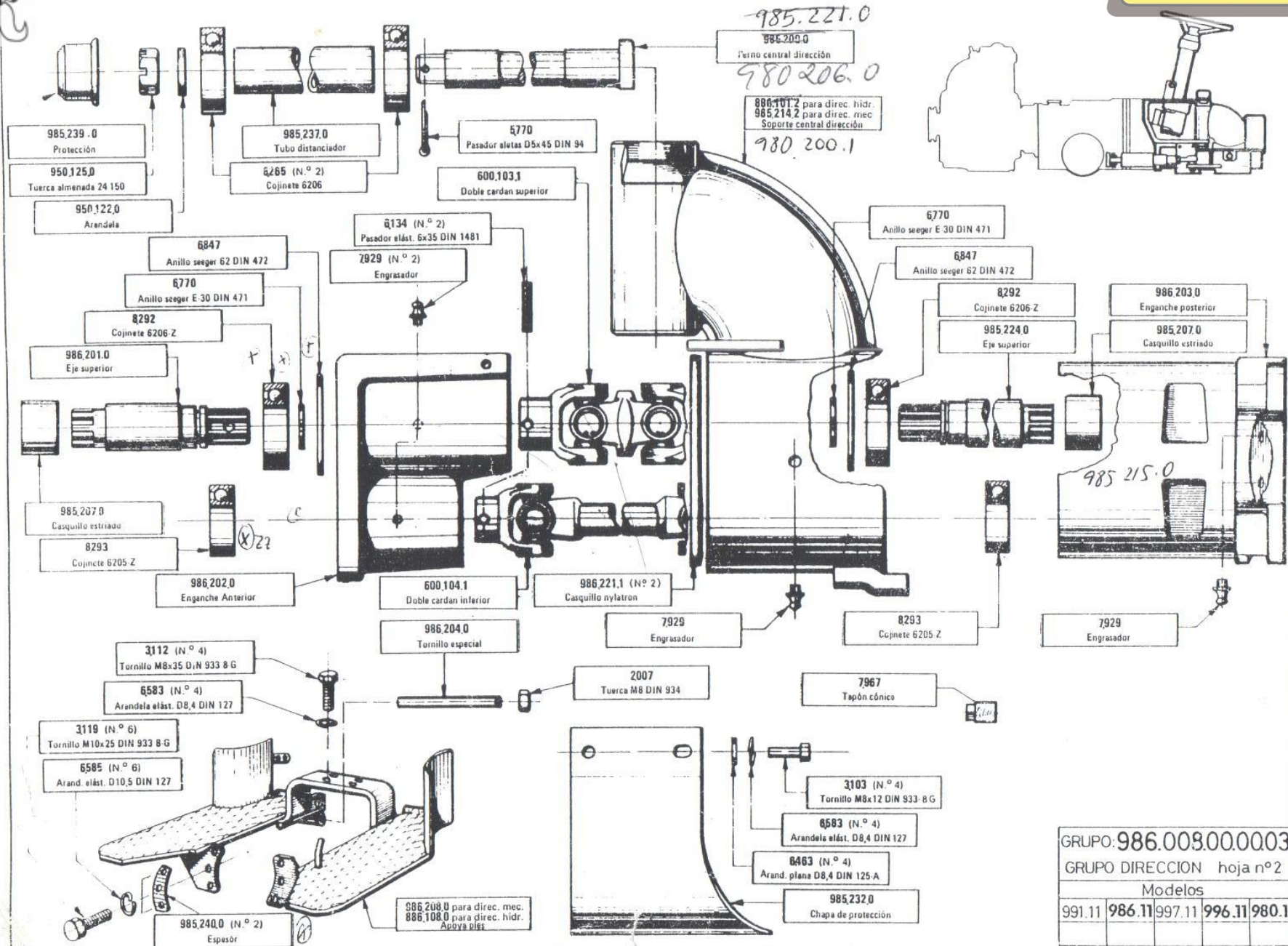

GRUPO: 986.008.00.0003			
GRUPO DIRECCION hoja nº 2			
Modelos			
991.11	986.11	997.11	996.11 980.11

JUNIO 81	EDICION
----------	---------

TRACTOR TIPO 980

pasquali

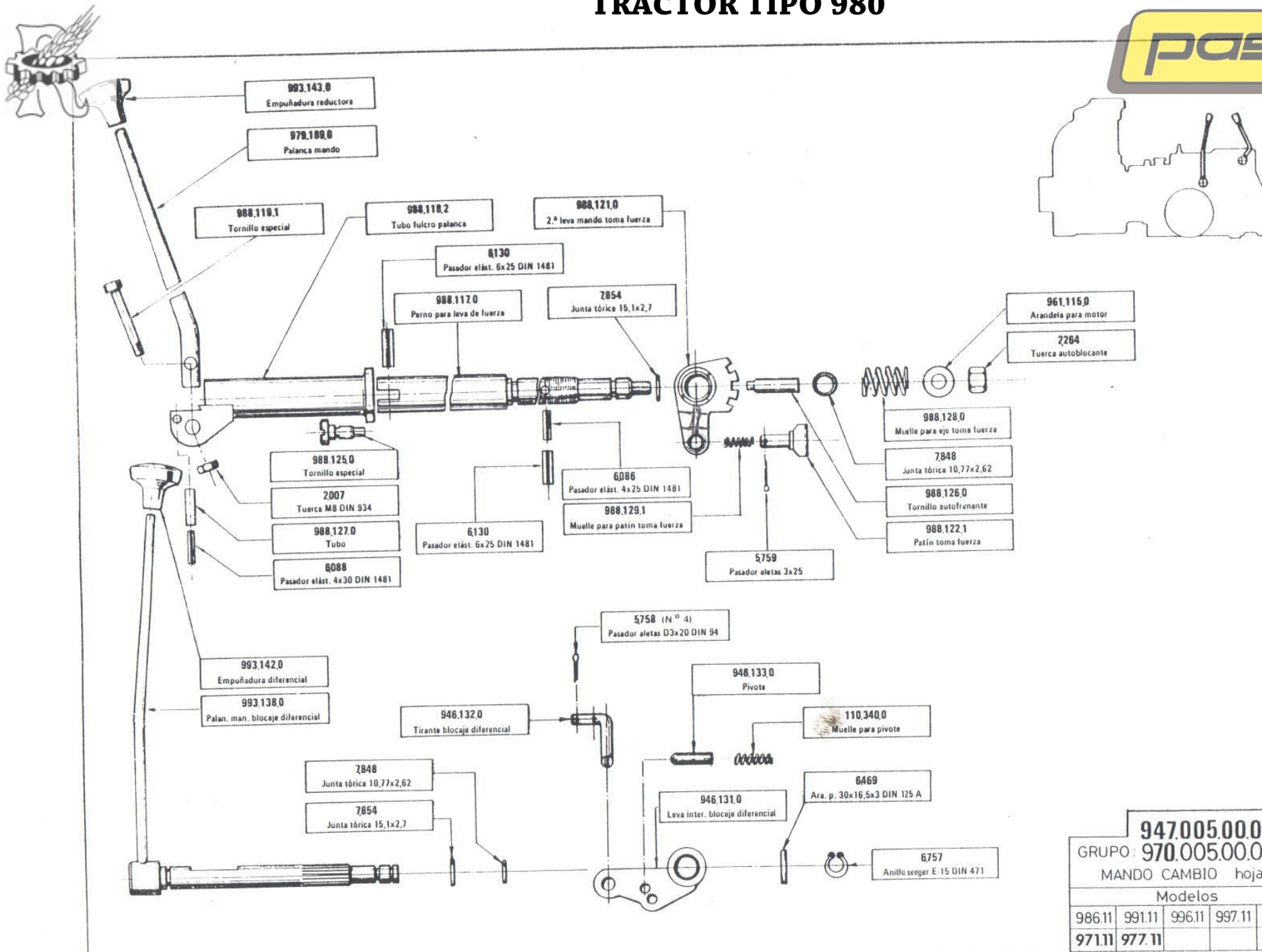

947.005.00.0002				
GRUPO: 970.005.00.0002				
MANDO CAMBIO hoja nº 2				
Modelos				
986.11	991.11	996.11	997.11	980.11
971.11	977.11			

JUNIO 81
EDICION

TRACTOR TIPO 980

pasquali

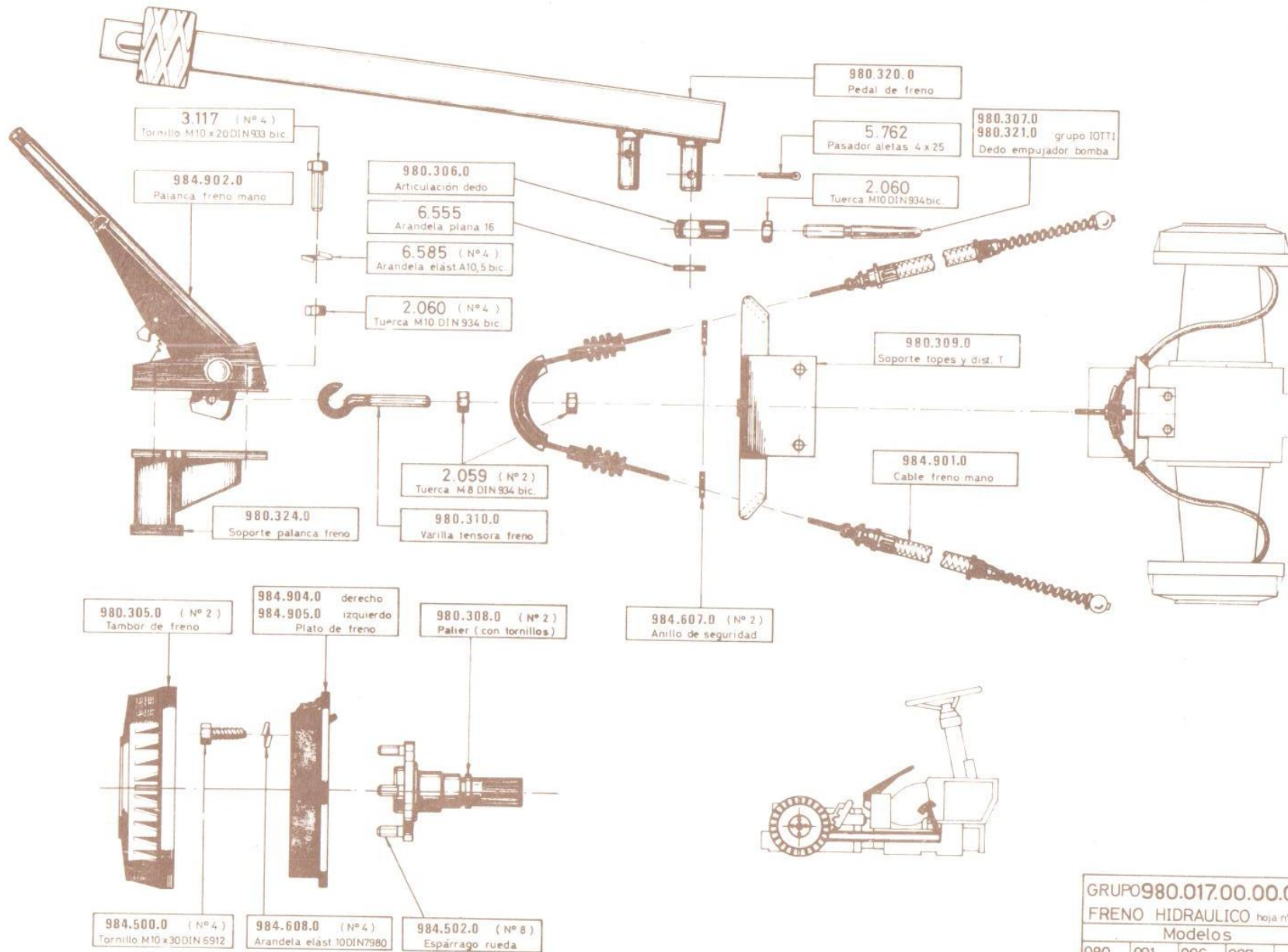

GRUPO 980.017.00.00.00

FRENO HIDRAULICO hoja n° 1

Modelos

980	991	996	997	
-----	-----	-----	-----	--

EDICION
Octubre 81
Marzo 83

TRACTOR TIPO 980

pasquali

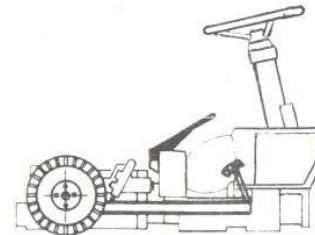
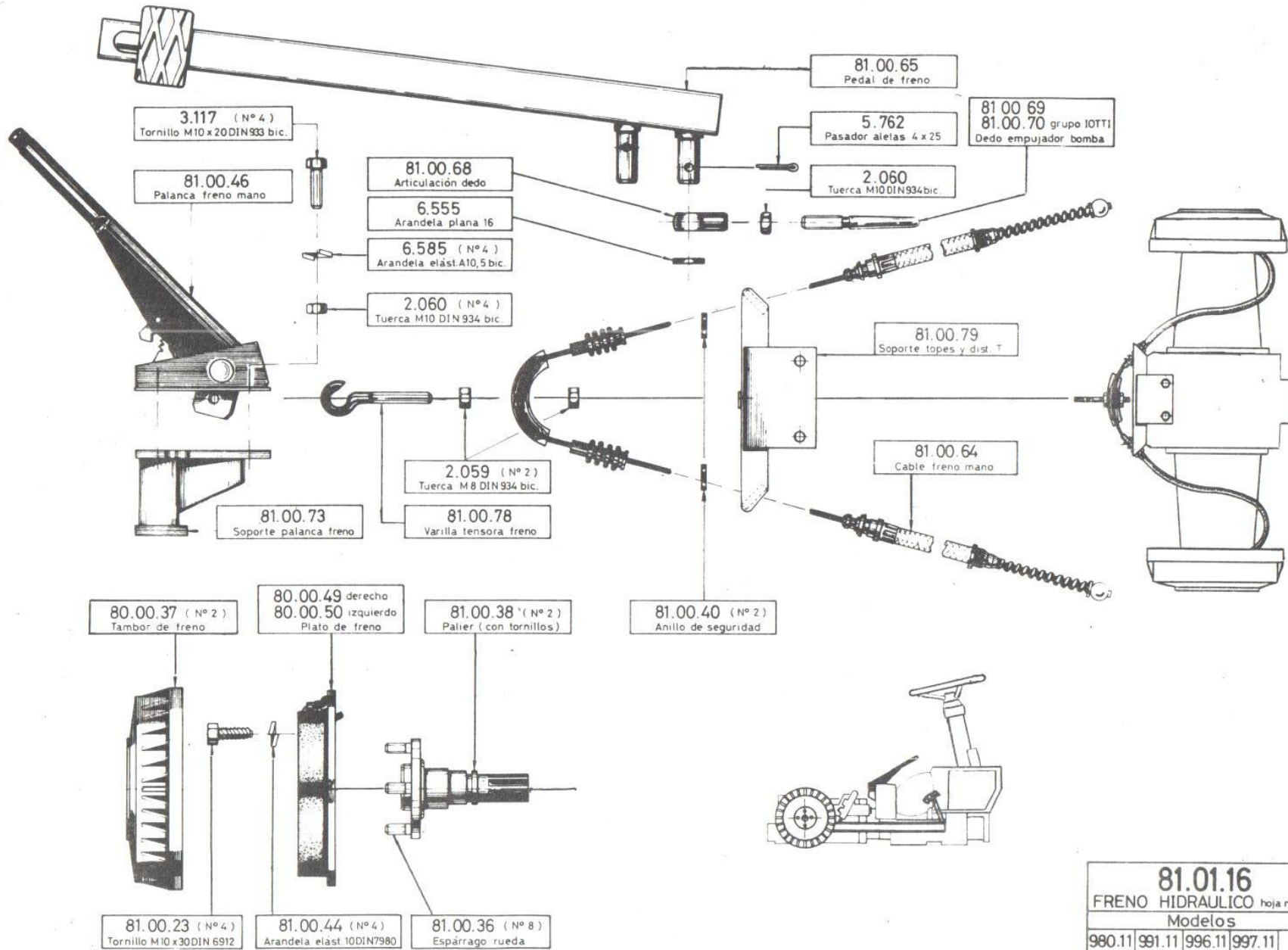

81.01.16			
FRENO HIDRAULICO hoja n° 1			
Modelos			
980.11	991.11	996.11	997.11

OCTUBRE 81	EDICION
------------	---------

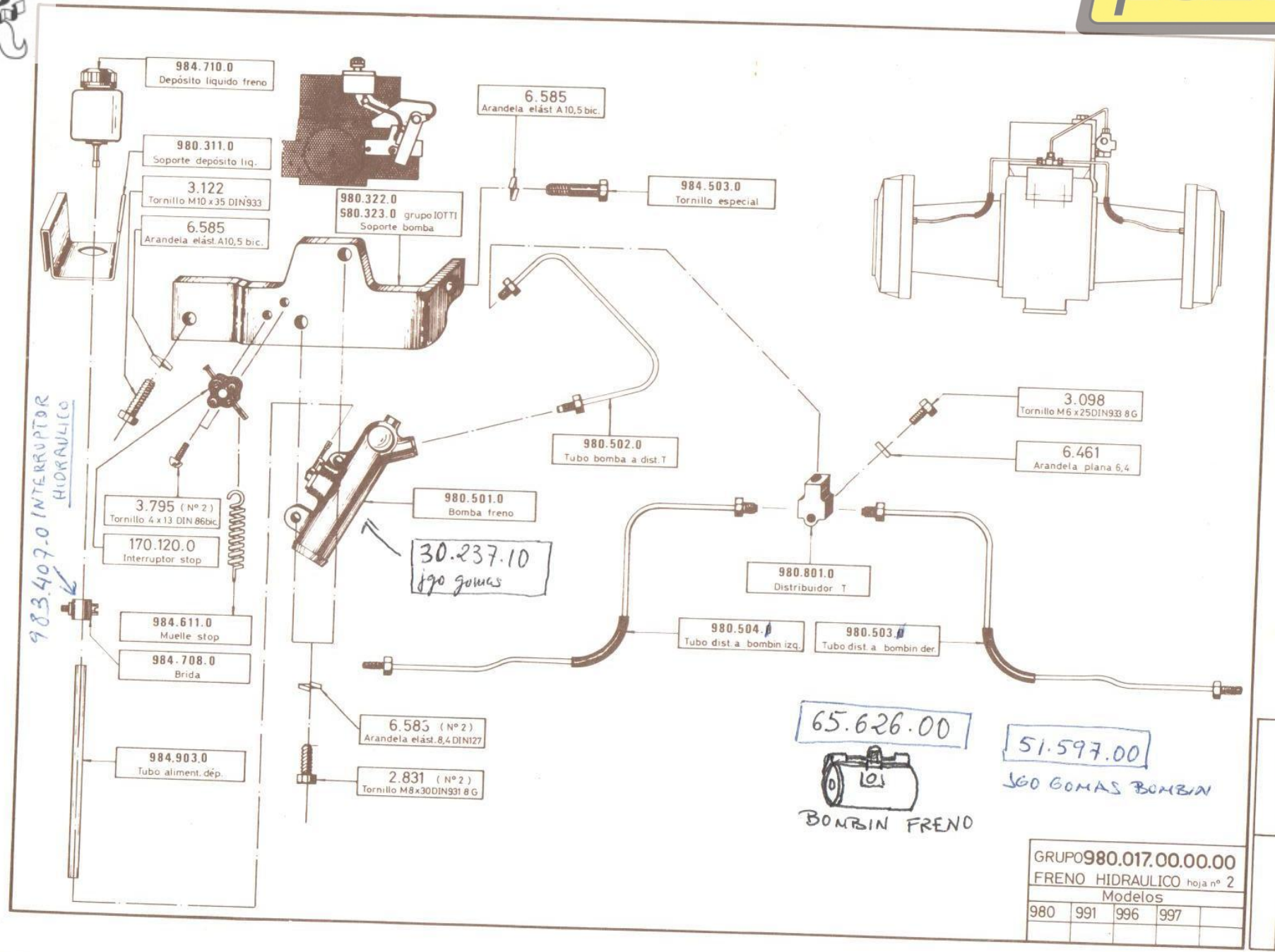

GRUPO 980.017.00.00.00
FRENO HIDRAULICO hoja nº 2
Modelos

980	991	996	997

EDICION	Octubre 81	Marzo 83
---------	------------	----------

